

VCE

range
(10 - 120)

» ELECTRIC WIRING



ISO 9001:2000 - Cert. n. 1368/1

ventilclima[®]
Apparecchi per la Climatizzazione

CENTRIFUGAL FAN COIL UNITS

ME VCE 10120 0604 VENTILCLIMA GB

INDEX

1.0 CONTROL BOARD WITHOUT THERMOSTAT	3
1.1 Control board view	3
1.2 Standard	3
1.3 Option: water low temperature thermostat	4
1.4 Option: valve	4
1.5 Option: valve + water low temperature thermostat	4
1.6 Option: 2 valves	5
1.7 Option: 2 valves + water low temperature thermostat	5
2.0 CONTROL BOARD WITH ELECTROMECHANICAL THERMOSTAT	6
2.1 Electromechanical thermostat view	6
2.2 Standard	6
2.3 Option: water low temperature thermostat	7
2.4 Option: valve (wiring harness "A")	7
2.5 Option: valve (wiring harness "B")	7
2.6 Option: valve + water low temperature thermostat	8
2.7 Option: 2 valves	8
2.8 Option: 2 valves + water low temperature thermostat	8
3.0 CONTROL BOARD WITH ELECTRONIC THERMOSTAT	9
3.1 Standard	9
3.2 Option: water low temperature thermosta	9
3.3 Option: valve (wiring harness "A")	9
3.4 Option: valve (wiring harness "B")	10
3.5 Option: valve + water low temperature thermostat	10
3.6 Option: 2 valves	11
3.7 Option: 2 valves + water low temperature thermostat	11
4.0 REMOTE CONTROL	12
4.1 Remote control TA/1 and TA/2	12
4.2 Remote control CD1	13
4.3 Electronic thermostat with 3 speeds control CD2/X1	14
4.4 Electronic thermostat with 3 speeds control CD2/X2	15
4.5 Electronic thermostat with 3 speeds control CD2/X4	16
4.6 Electronic thermostat with 3 speeds control CD3/V e CD3/N	17
4.7 Electronic thermostat with 3 speeds control CDR	18
4.8 Electronic thermostat with 3 speeds control CD2/ZN	19
4.9 Interface chart for the control of 4 fan-coils SDI	20

2



1.0 CONTROL BOARD WITHOUT THERMOSTAT

1.1 CONTROL BOARD VIEW

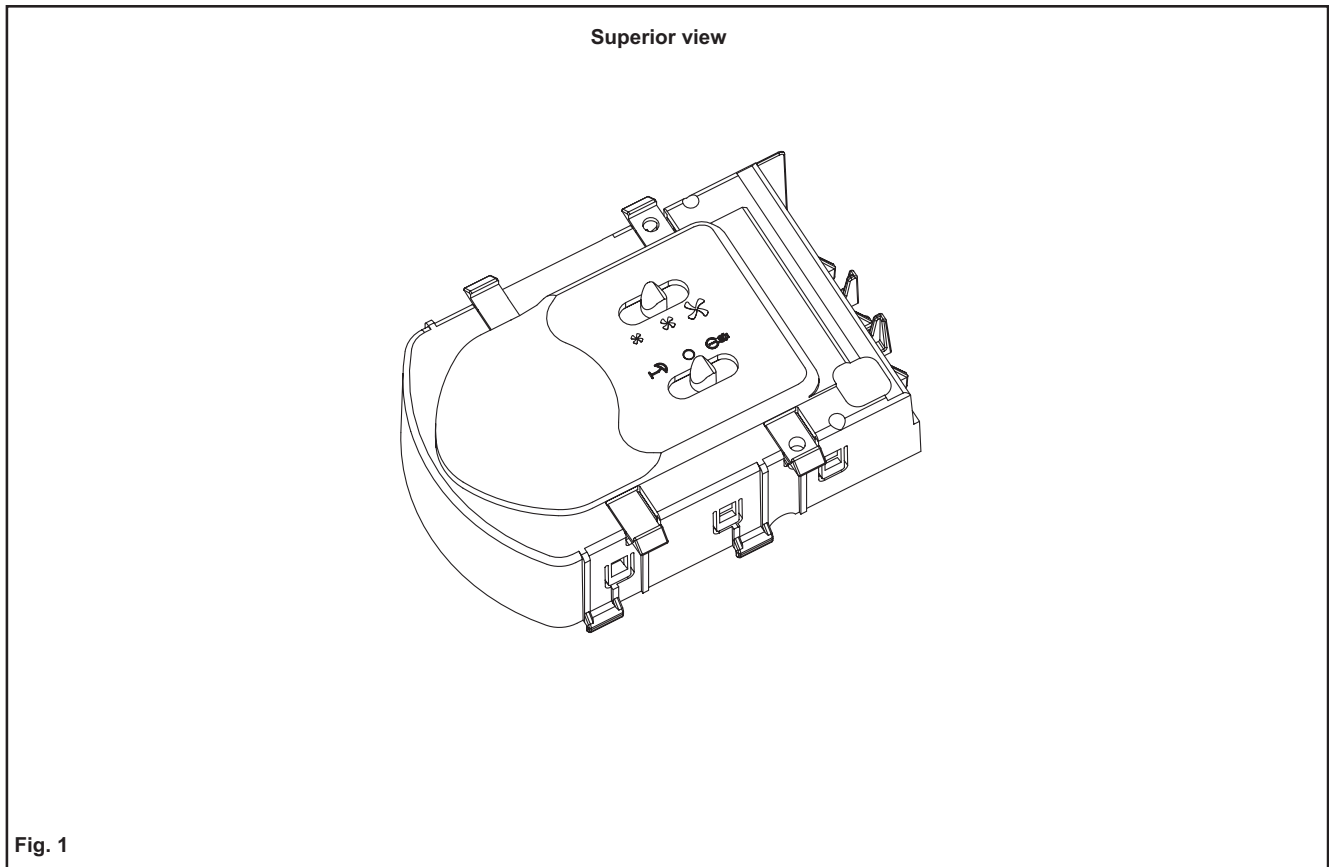

Fig. 1

1.2 STANDARD

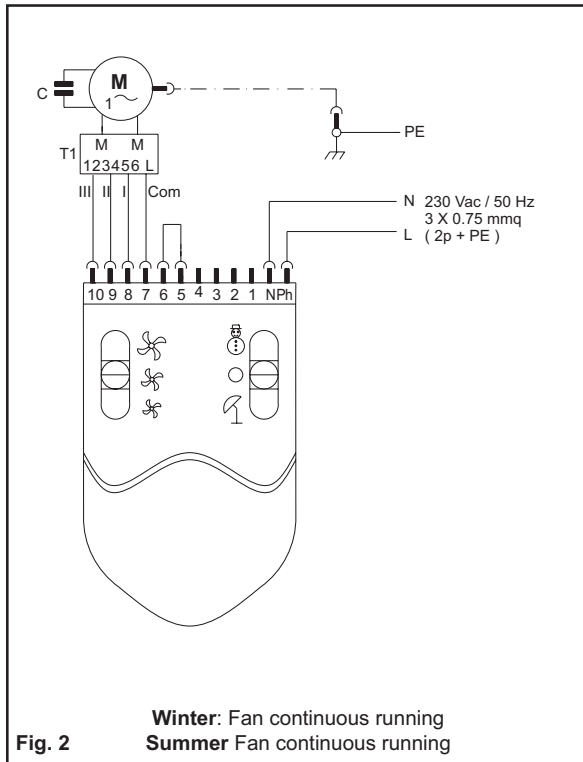
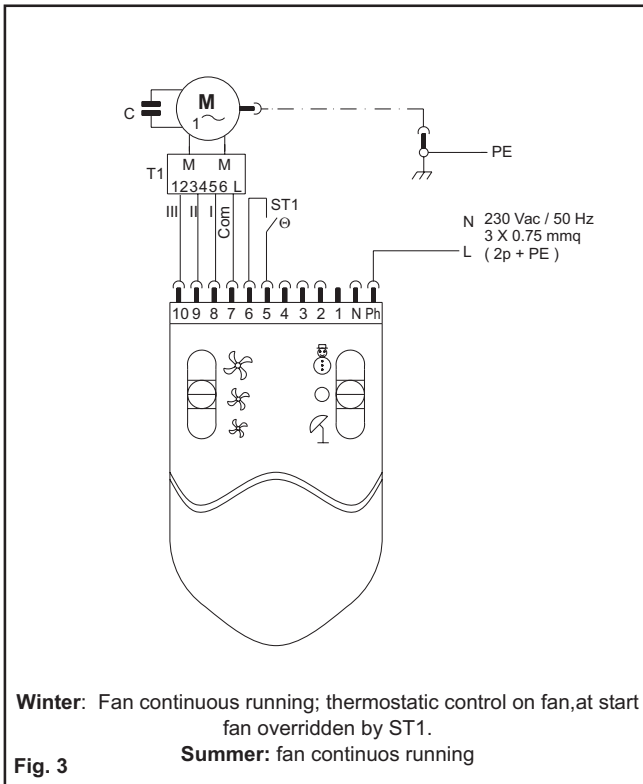

Fig. 2

LEGEND:

- PE** PROTECTIVE CONDUCTOR (yellow/green)
- N** NEUTRAL (blue)
- L** PHASE (brown)
- M** FAN MOTOR
- Com** COMMON (white)
- I** MINIMUM SPEED (red)
- II** MEDIUM SPEED (blue)
- III** MAXIMUM SPEED (black)
- T1** AUTOTRANSFORMER

1.3 OPTION: WATER LOW TEMPERATURE THERMOSTAT



1.4 OPTION: VALVE

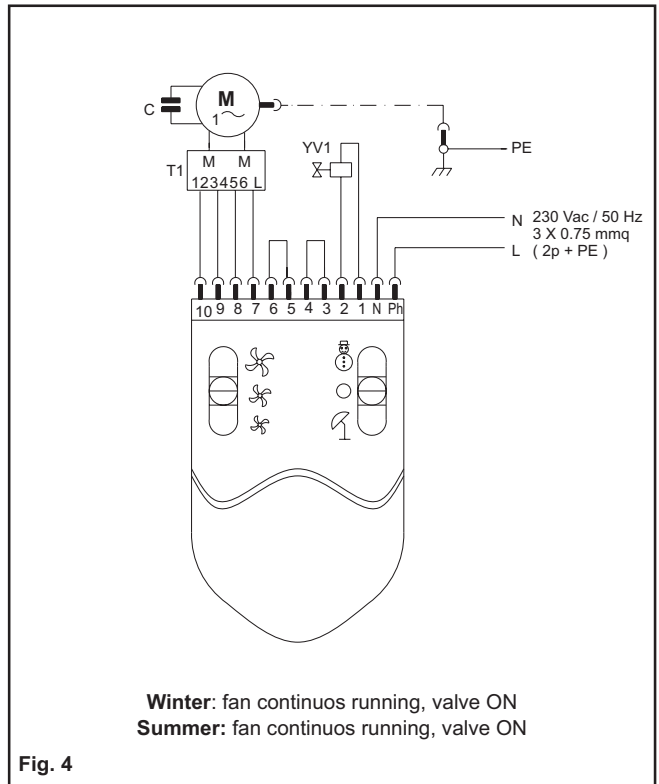

4

1.5 OPTION: VALVE + WATER LOW TEMPERATURE THERMOSTAT

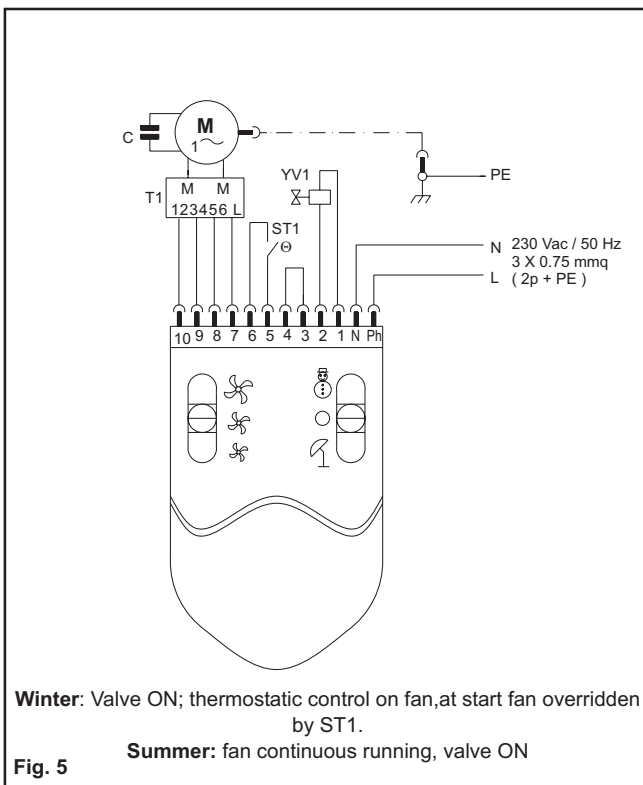

LEGEND:

- PE PROTECTIVE CONDUCTOR (yellow/green)
- N NEUTRAL (blue)
- L PHASE (brown)
- M FAN MOTOR
- Com COMMON (white)
- I MINIMUM SPEED (red)
- II MEDIUM SPEED (blue)
- III MAXIMUM SPEED (black)
- T1 AUTOTRANSFORMER
- YV1 HEAT/COOL VALVE
- ST1 WATER LOW TEMPERATURE THERMOSTAT

1.6 OPTION: 2 VALVE

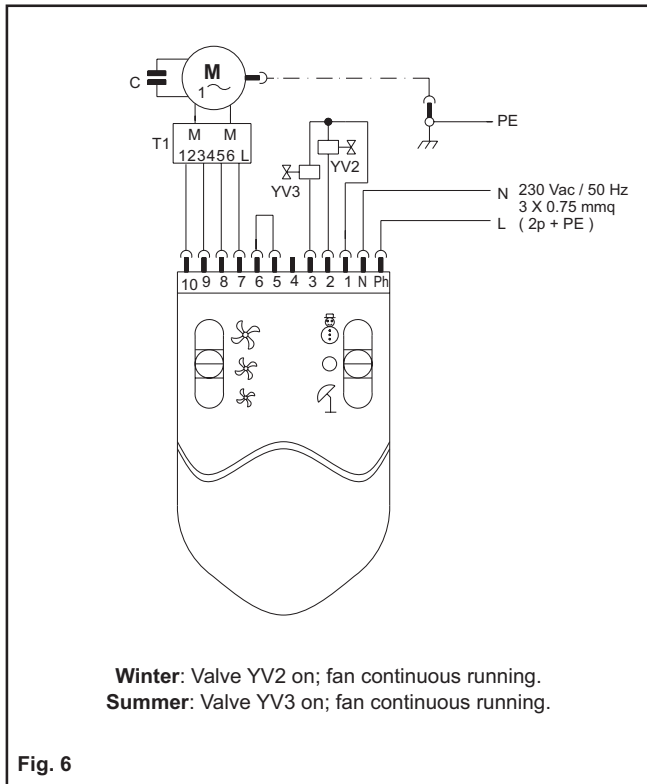

1.7 OPTION: 2 VALVE + WATER LOW TEMPERATURE THERMOSTAT

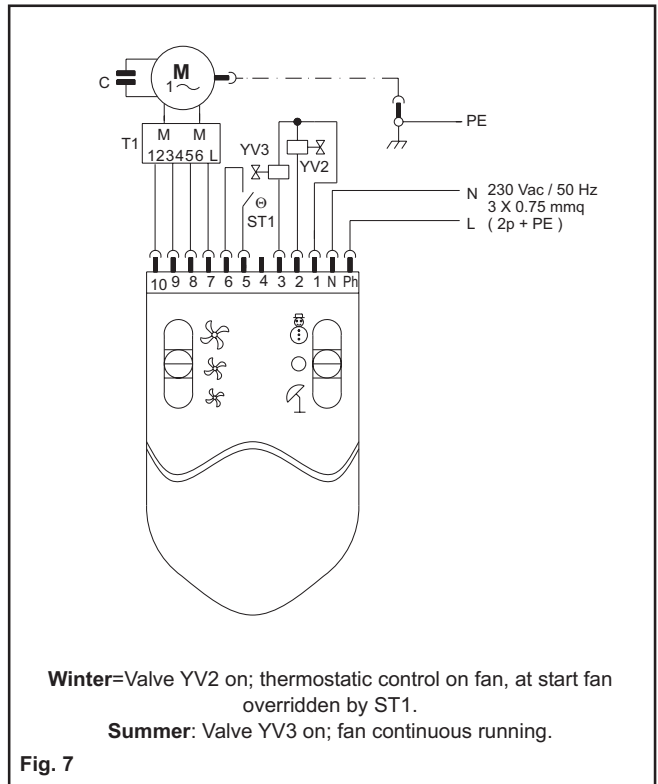

LEGEND:

- PE** PROTECTIVE CONDUCTOR (yellow/green)
- N** NEUTRAL (blue)
- L** PHASE (brown)
- M** FAN MOTOR
- Com** COMMON (white)
- I** MINIMUM SPEED (red)
- II** MEDIUM SPEED (blue)
- III** MAXIMUM SPEED (black)
- T1** AUTOTRANSFORMER
- YV1** HEAT/COOL VALVE
- YV2** HEAT VALVE
- YV3** COOL VALVE
- ST1** WATER LOW TEMPERATURE THERMOSTAT

2.0 CONTROL BOARD WITH ELECTROMECHANICAL THERMOSTAT

2.1 ELECTROTHERMOSTAT VIEW

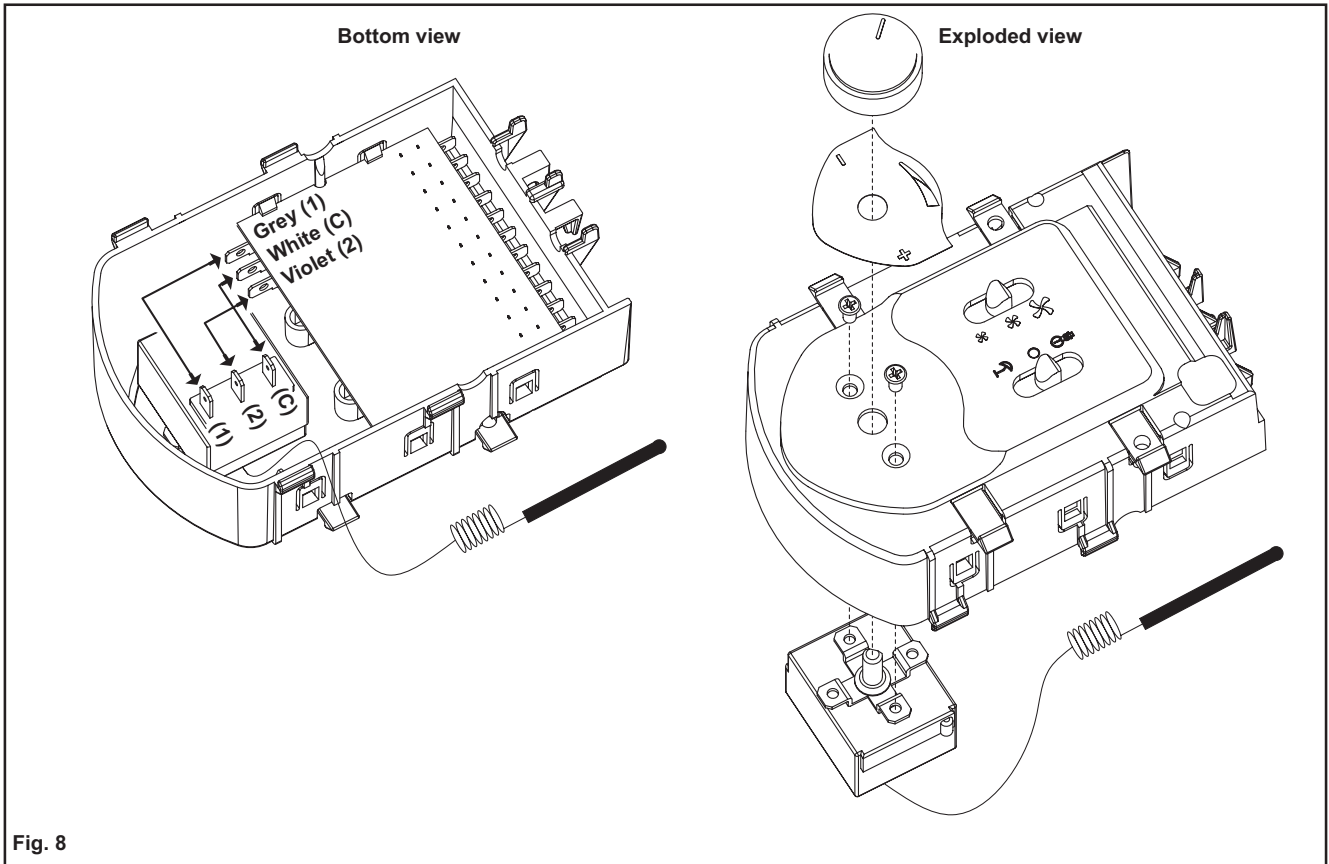

6

Fig. 8

2.2 STANDARD

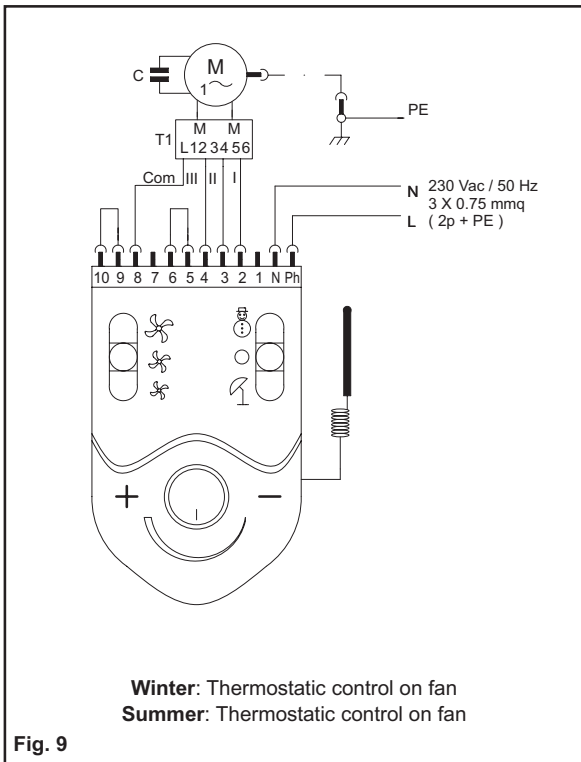
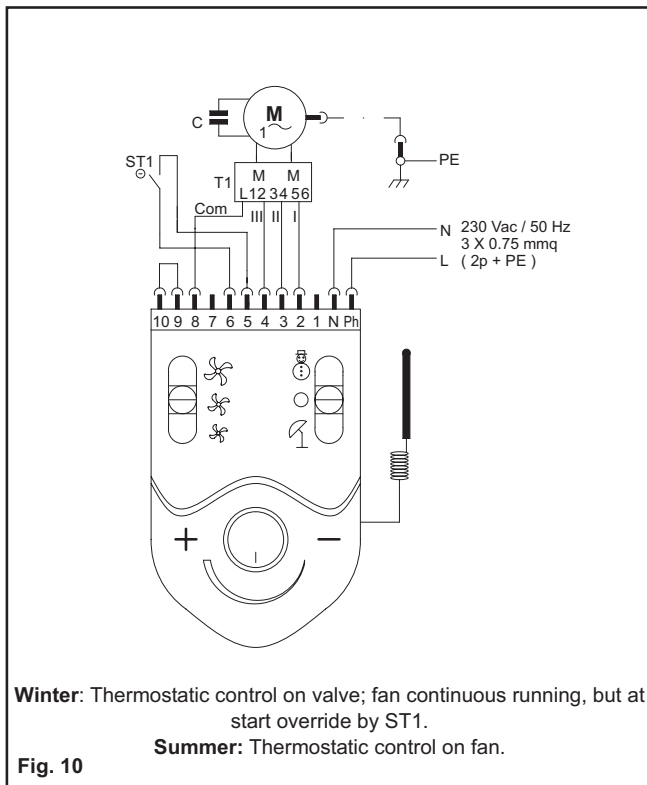

Fig. 9

LEGEND:

- PE** PROTECTIVE CONDUCTOR (yellow/green)
- N** NEUTRAL (blue)
- L** PHASE (brown)
- M** FAN MOTOR
- Com** COMMON (white)
- I** MINIMUM SPEED (red)
- II** MEDIUM SPEED (blue)
- III** MAXIMUM SPEED (black)
- T1** AUTOTRANSFORMER
- ST1** WATER LOW TEMPERATURE THERMOSTAT

2.3 OPTION: WATER LOW TEMPERATURE THERMOSTAT



2.4 OPTION: VALVE (WIRING HARNESS "A")

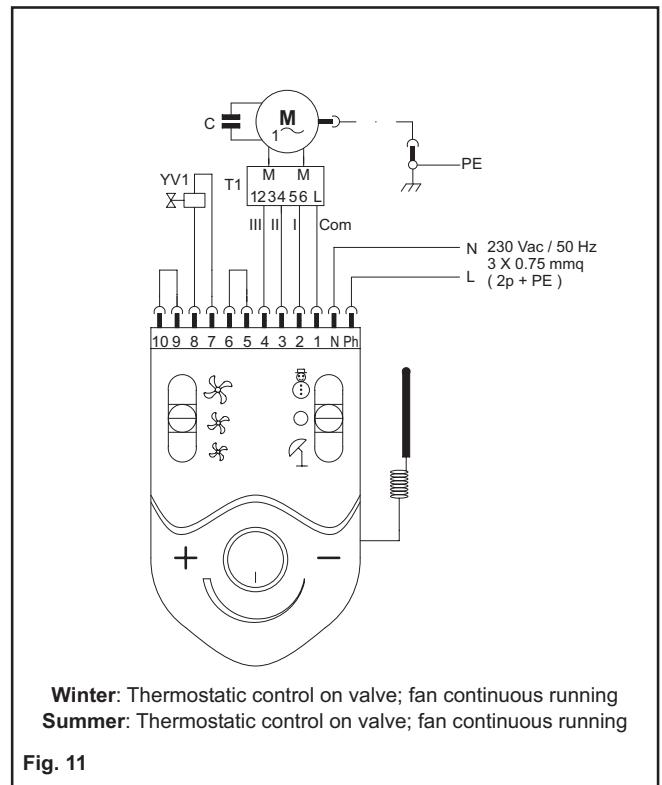

2.5 OPTION: VALVE (WIRING HARNESS "B")

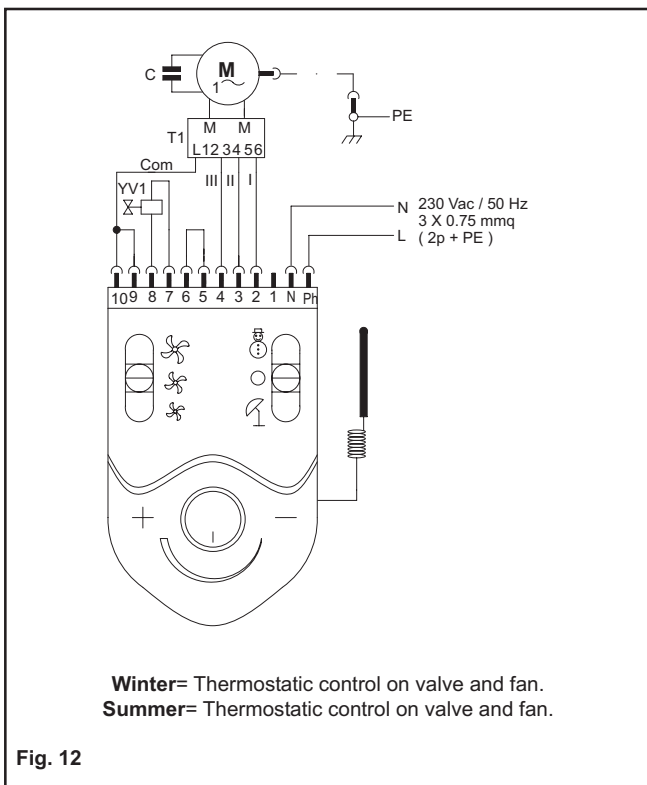

- LEGEND:**
- PE** PROTECTIVE CONDUCTOR (yellow/green)
 - N** NEUTRAL (blue)
 - L** PHASE (brown)
 - M** FAN MOTOR
 - Com** COMMON (white)
 - I** MINIMUM SPEED (red)
 - II** MEDIUM SPEED (blue)
 - III** MAXIMUM SPEED (black)
 - T1** AUTOTRANSFORMER
 - YV1** HEAT/COOL VALVE
 - ST1** WATER LOW TEMPERATURE THERMOSTAT

2.6 OPTION: VALVE + WATER LOW TEMPERATURE THERMOSTAT

2.7 OPTION: 2 VALVE

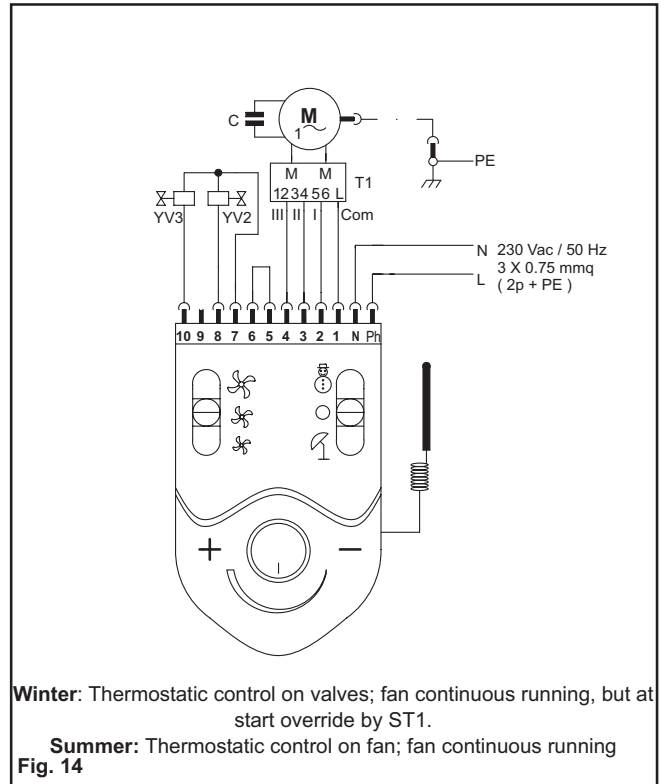
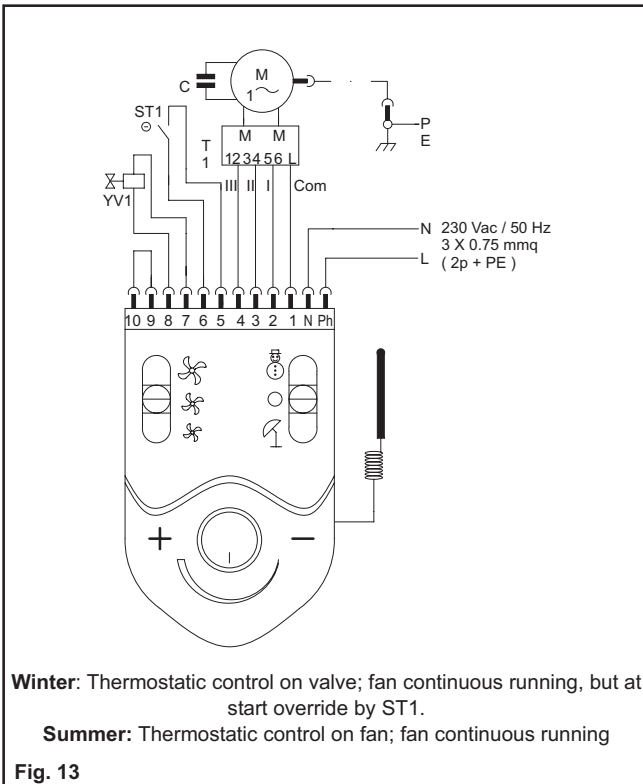

8

2.8 OPTION: 2 VALVES+WATER LOW TEMPERATURE THERMOSTAT

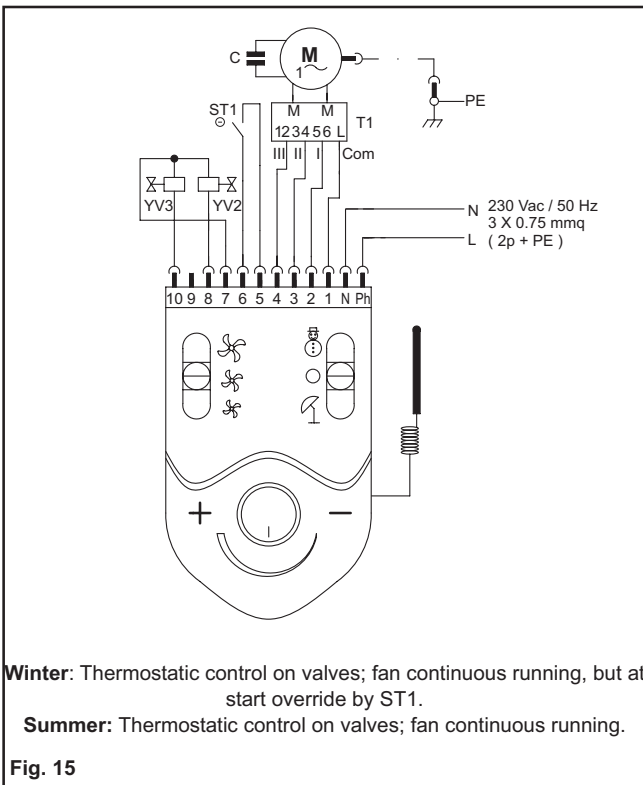

LEGEND:

- PE** PROTECTIVE CONDUCTOR (yellow/green)
- N** NEUTRAL (blue)
- L** PHASE (brown)
- M** FAN MOTOR
- Com** COMMON (white)
- I** MINIMUM SPEED (red)
- II** MEDIUM SPEED (blue)
- III** MAXIMUM SPEED (black)
- T1** AUTOTRANSFORMER
- YV1** HEAT/COOL VALVE
- YV2** HEAT VALVE
- YV3** COOL VALVE
- ST1** WATER LOW TEMPERATURE THERMOSTAT

3.0 CONTROL BOARD WITH ELECTRIC THERMOSTAT

3.1 STANDARD

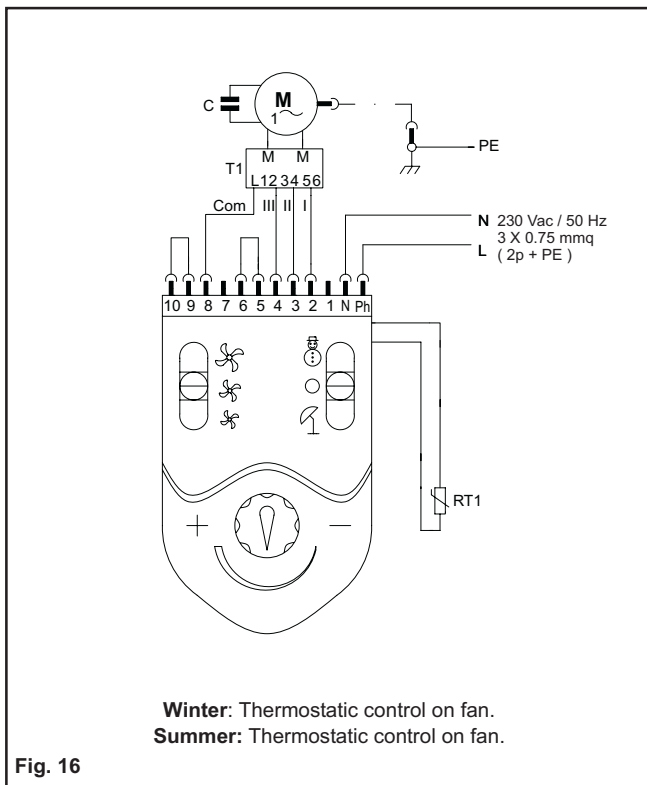

3.2 OPTION: WATER LOW TEMPERATURE THERMOSTAT

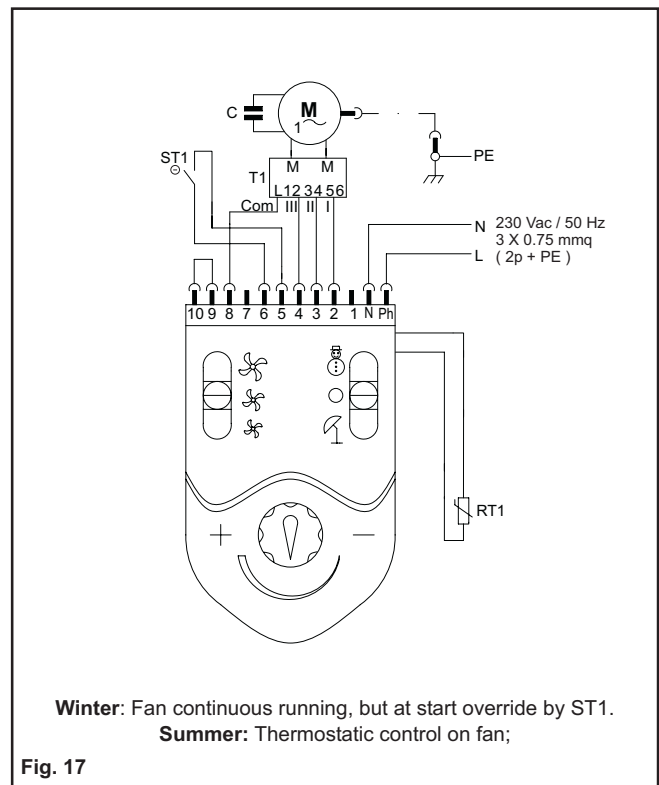

3.3 OPTION: VALVE (WIRING HARNESS "A")

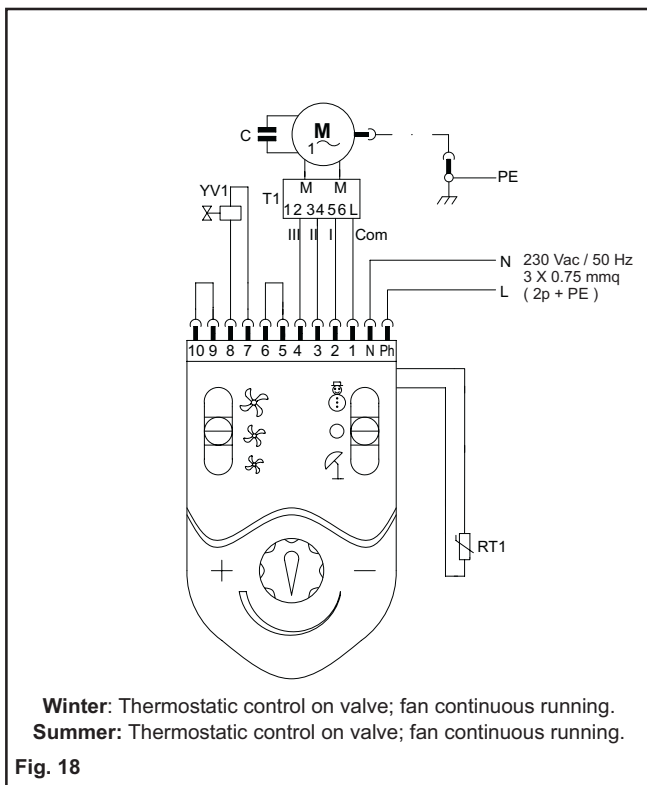

LEGEND:

- PE** PROTECTIVE CONDUCTOR (yellow/green)
- N** NEUTRAL (blue)
- L** PHASE (brown)
- M** FAN MOTOR
- Com** COMMON (white)
- I** MINIMUM SPEED (red)
- II** MEDIUM SPEED (blue)
- III** MAXIMUM SPEED (black)
- T1** AUTOTRANSFORMER
- YV1** HEAT/COOL VALVE
- ST1** WATER LOW TEMPERATURE THERMOSTAT
- RT1** ROOM TEMPERATURE SENSOR

3.4 OPTION: VALVE (WIRING HARNESS "B")

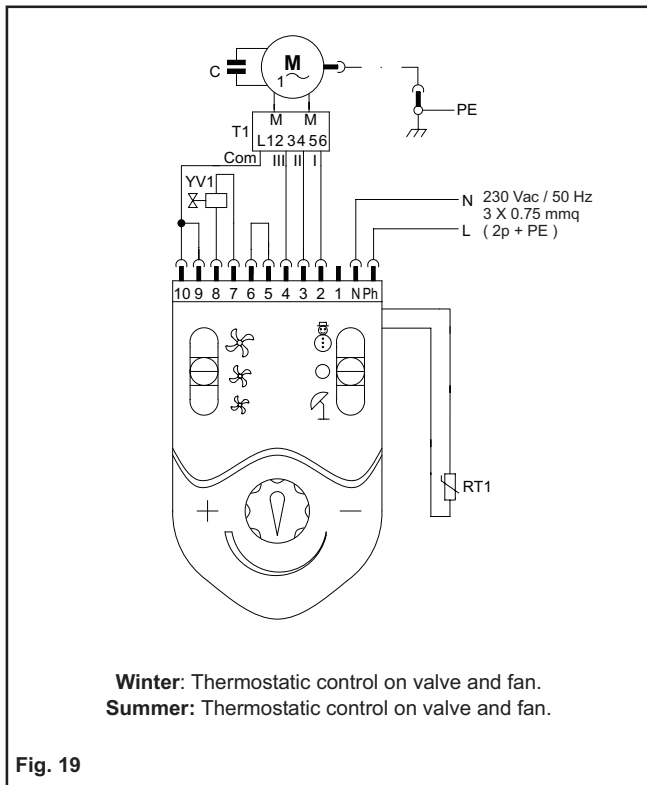

3.5 OPTION: VALVE + WATER LOW TEMPERATURE THERMOSTAT

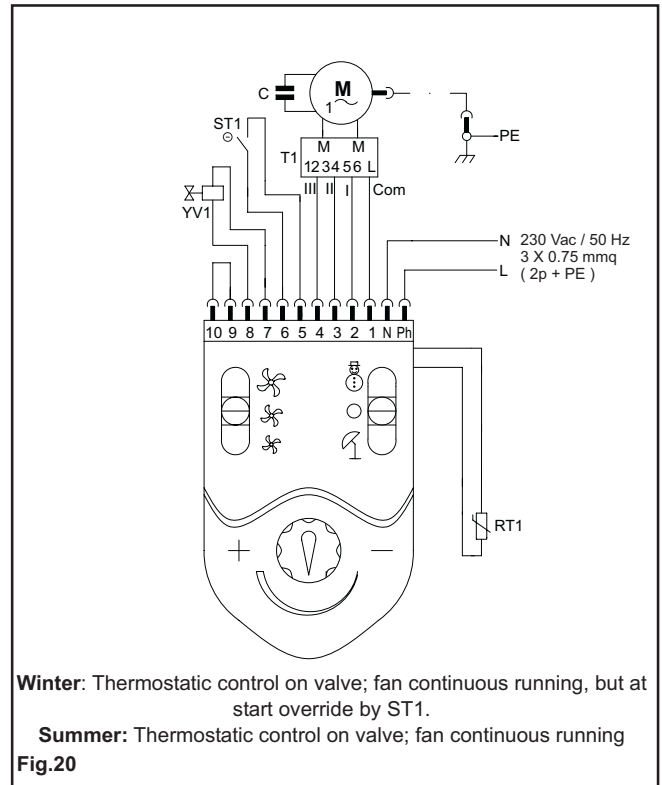

10

3.6 OPTION: 2 VALVES

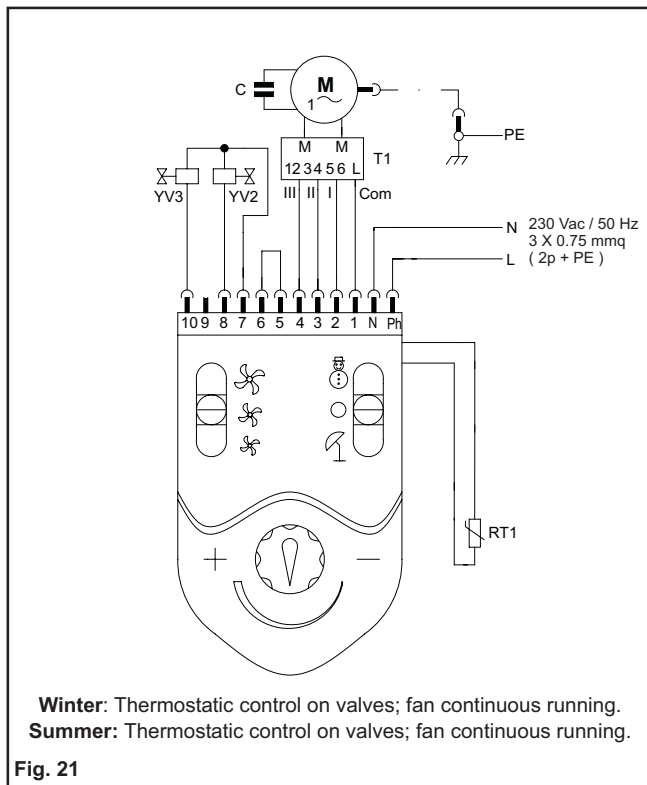

LEGEND:

- PE PROTECTIVE CONDUCTOR (yellow/green)
- N NEUTRAL (blue)
- L PHASE (brown)
- M FAN MOTOR
- Com COMMON (white)
- I MINIMUM SPEED (red)
- II MEDIUM SPEED (blue)
- III MAXIMUM SPEED (black)
- T1 AUTOTRANSFORMER
- YV1 HEAT/COOL VALVE
- ST1 WATER LOW TEMPERATURE THERMOSTAT
- RT1 ROOM TEMPERATURE SENSOR

3.7 OPTION: 2 VALVES + WATER LOW TEMPERATURE THERMOSTAT

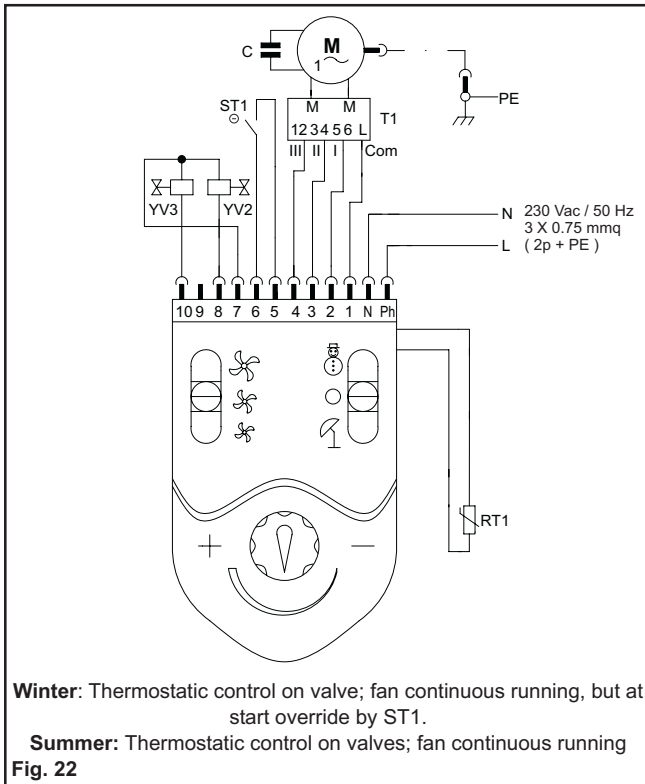

LEGEND:

- PE** PROTECTIVE CONDUCTOR (yellow/green)
- N** NEUTRAL (blue)
- L** PHASE (brown)
- M** FAN MOTOR
- Com** COMMON (white)
- I** MINIMUM SPEED (red)
- II** MEDIUM SPEED (blue)
- III** MAXIMUM SPEED (black)
- T1** AUTOTRANSFORMER
- YV2** HEAT VALVE
- YV3** COOL VALVE
- ST1** WATER LOW TEMPERATURE THERMOSTAT

4.0 REMOTE CONTROL

4.1 REMOTE CONTROL TA/1 AND TA/2

The standard remote electronic room thermostat TA has an OFF/SUMMER/WINTER switch and a control light. It is extremely versatile, suitable for use both in heating as well in air conditioning. The TA/1 thermostat is without display, while the TA/2 has a 3"1/2 display for the room temperature reading.

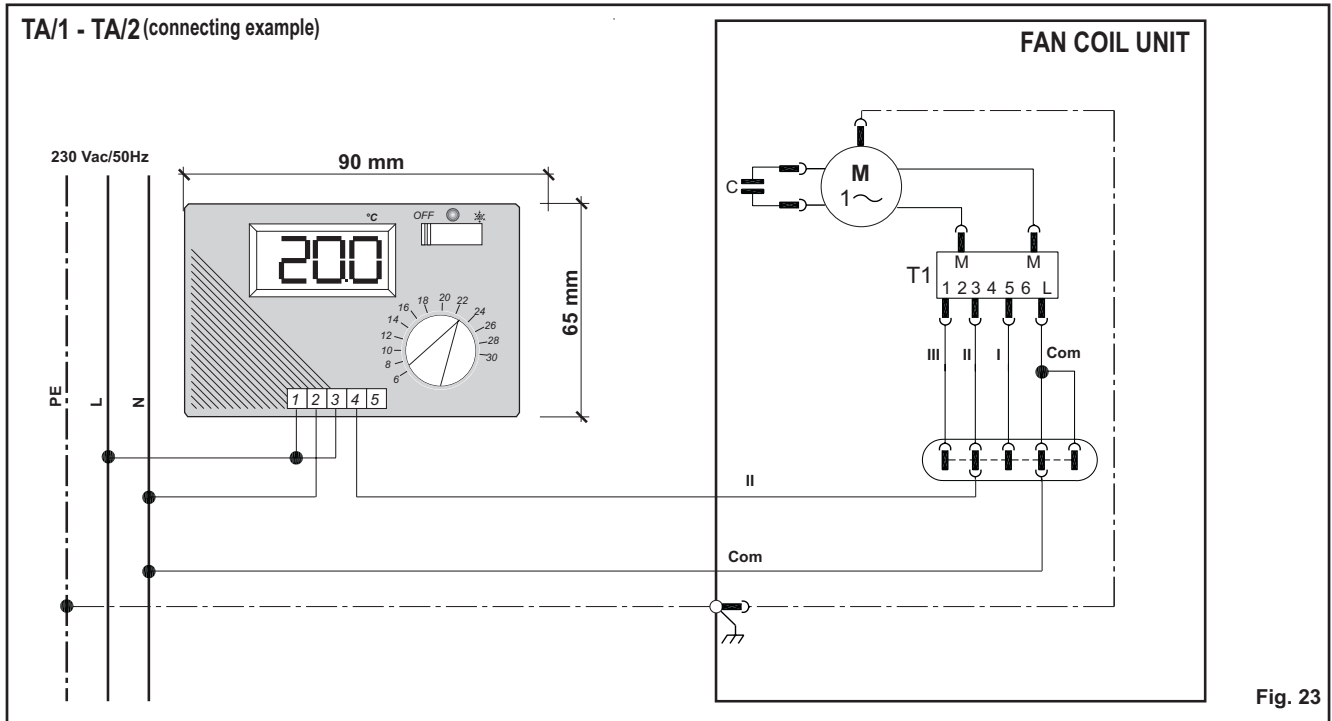

Fig. 23

12

LEGEND:

PE PROTECTIVE CONDUCTOR (yellow/green)
N NEUTRAL
L PHASE
M FAN MOTOR
Com COMMON (white)

I MINIMUM SPEED (red)
II MEDIUM SPEED (blue)
III MAXIMUM SPEED (black)
T1 AUTOTRANSFORMER (excluded VCE 80-90-100 model)

Electrical supply	230 ±10%V/1/50-60Hz
Max. power dissipation	1VA
Inlet	internal sensor or semiconductor
Outlet	Relay 6 A, 250 V
Intervention differential	0,5°C
Settings	OFF-summer-winter
Set point adjustment	6-30°C
Resolution	0,1°C
Temperature limits	0-50°C
Humidity limits	10-90%U.R.
Signals	Led rosso
Display	3"1/2 liquid crystal
Container	ABS IP30
Dimensions	90 x 65 x 30 mm
Weight	130 g

4.2 REMOTE ONTROL CD1

The remote control CD1, by means of two switches, allows the remote control of a 3 speed fan coil. A

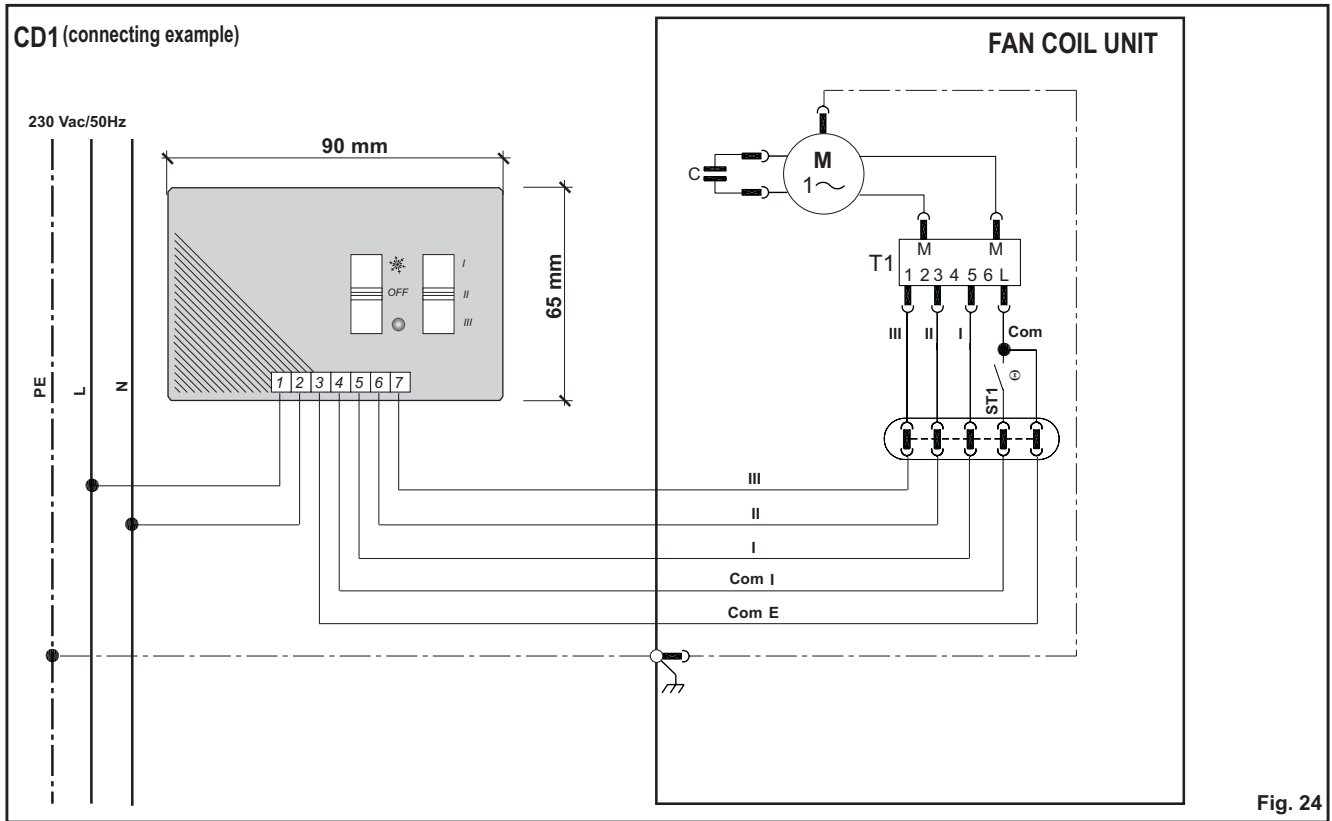

Fig. 24

LEGEND:

- PE** PROTECTIVE CONDUCTOR (yellow/green)
- N** NEUTRAL
- L** PHASE
- M** FAN MOTOR
- Com** COMMON (white)
- Com E** SUMMER COMMON

- I** MINIMUM SPEED (red)
- II** MEDIUM SPEED (blue)
- III** MAXIMUM SPEED (black)
- T1** AUTOTRANSFORMER (excluded VCE 80-90-100 model)
- Com I** WINTER COMMON
- ST1** WATER LOW TEMPERATURE THERMOSTAT

Electrical supply	230 ±10%V/1/50-60Hz
Max power dissipation	1VA
Outlet	Relay 6 A, 250 V
Settings	OFF-summer-winter
Temperature limits	0-50°C
Humidity limits	10-90%U.R.
Container	ABS IP30
Dimensions	90 x 65 x 30 mm
Weight	130 g

4.3 ELECTRONIC THERMOSTAT WITH 3 SPEED CONTROLCD2/X1

By means of 2 switches, allow the remote control of a 3 speed fan coil. A switch selects the function OFF-summer-winter while the other selects one of the three speed. The switch selects one of the two functions:

- **SUMMER:** start of the motor and consensus to the valve when the temperature rises;
 - **WINTER:** start of the motor and consensus to the valve when the temperature decreases;
- or start of the motor by consensus of the minimum temperature thermostat (without valve)

NOTE: It is possible to connect only the ST1 or only YV1, but not both together.

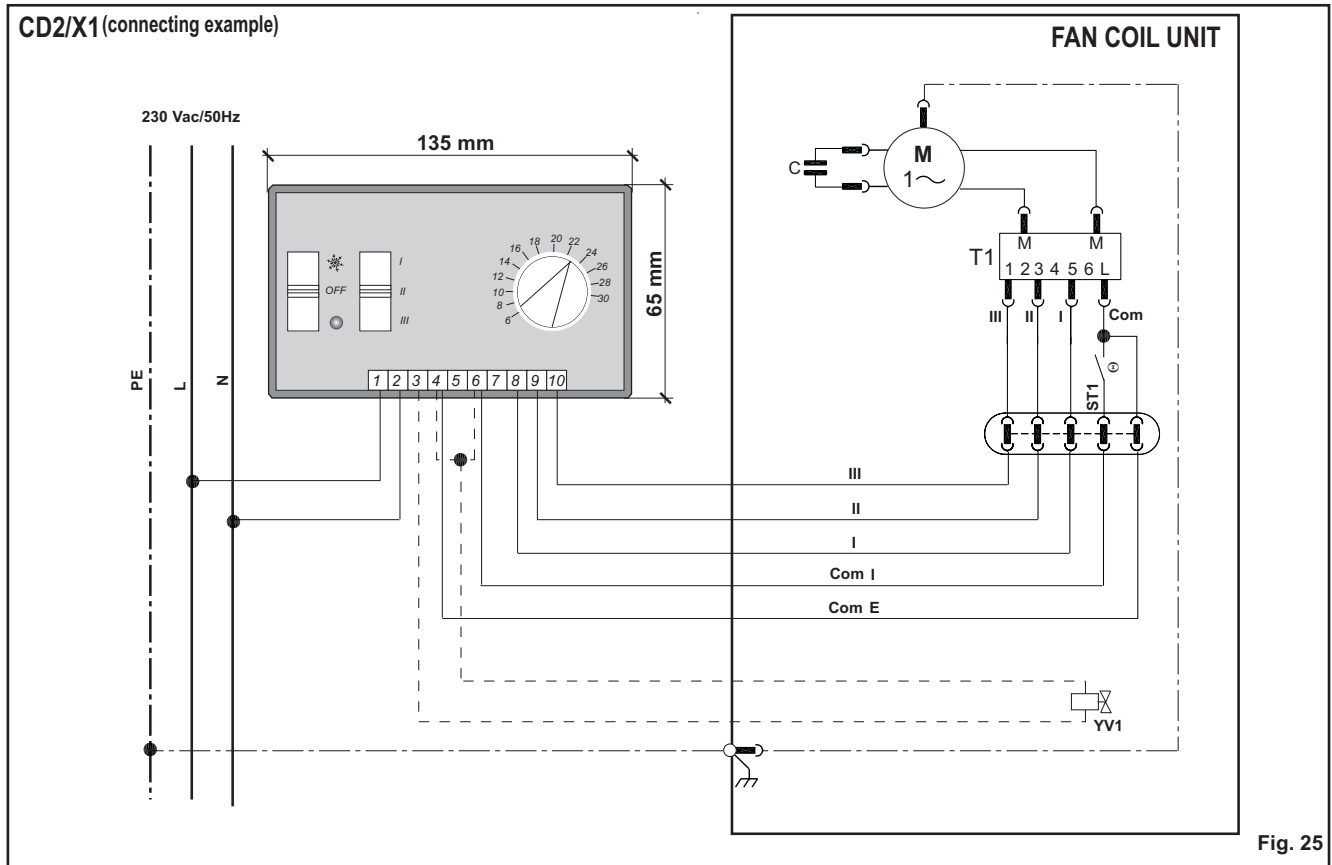

14

LEGEND:

PE PROTECTIVE CONDUCTOR (yellow/green)
N NEUTRAL
L PHASE
M FAN MOTOR
Com COMMON (white)
Com E SUMMER COMMON
YV1 HEAT/COOL VALVE

I MINIMUM SPEED (red)
II MEDIUM SPEED (blue)
III MAXIMUM SPEED (black)
T1 AUTOTRANSFORMER (excluded VCE 80-90-100 model)
Com I WINTER COMMON
ST1 WATER LOW TEMPERATURE THERMOSTAT

Electrical supply	230 ±10%V/1/50-60Hz
Max power dissipated	1VA
Feeler	PTC
Outlet	Relay 6 A, 250 V
Intervention differential	0,5°C
Settings	OFF-summer-winter / 3 speeds
Set point adjustment	6-30°C
Temperature limits	0-50°C
Humidity limits	10-90%U.R.
Container	ABS IP30
Dimensions	135 x 65 x 30 mm
Weight	130 g

4.4 ELECTRONIC THERMOSTAT WITH 3 SPEED CONTROL CD2/X2

By means of 2 switches, allow the remote control of a 3 speed fan coil. A switch selects the function OFF-summer-winter while the other selects one of the three speed. The switch selects one of the two functions:

- **SUMMER:** consensus to the valve COOL when the temperature rises, motor always on;
- **WINTER:** consensus to the valve HEAT when the temperature decreases, motor always on with consensus of the minimum temperature thermostat;

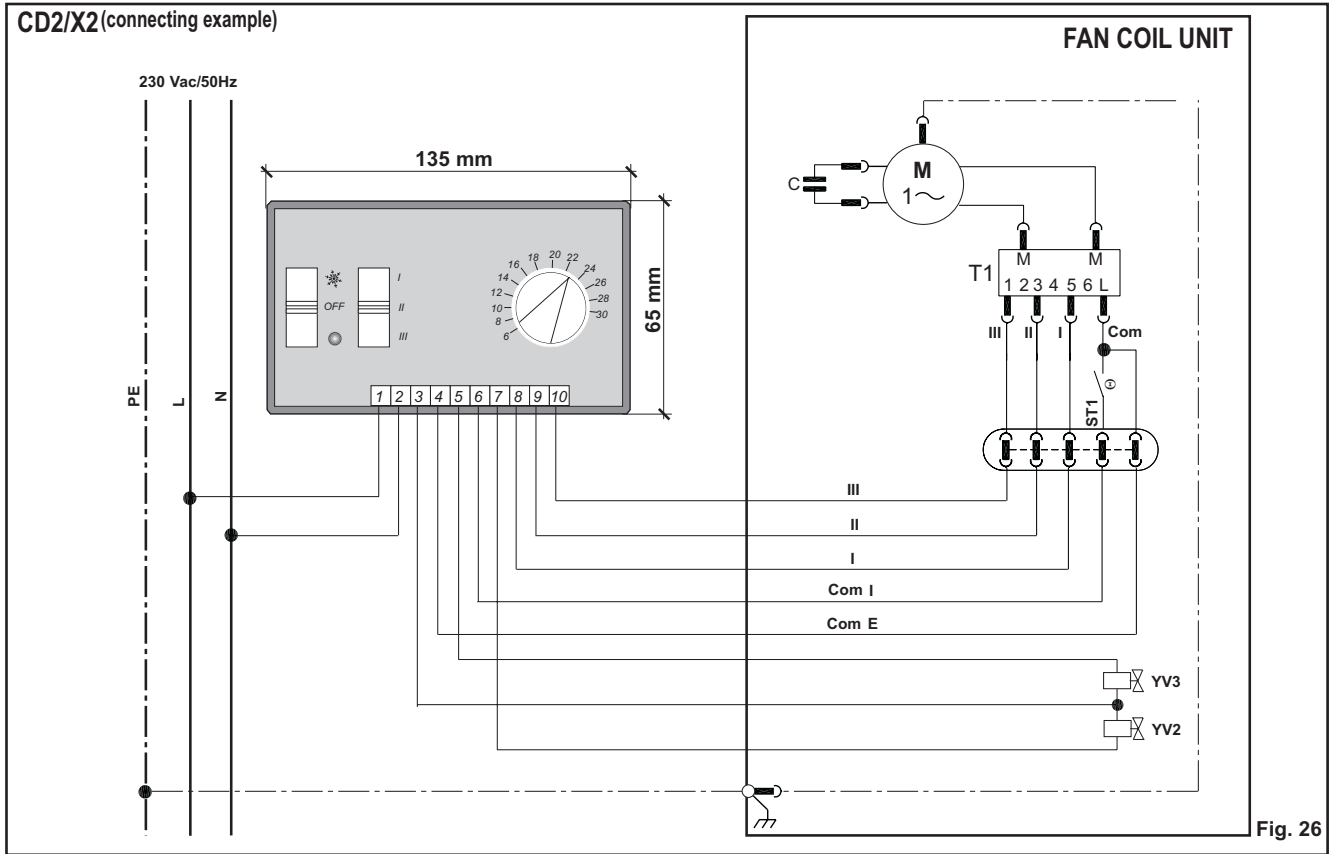

Fig. 26

LEGEND:

- PE** PROTECTIVE CONDUCTOR (yellow/green)
- N** NEUTRAL
- L** PHASE
- M** FAN MOTOR
- Com** COMMON (white)
- Com E** SUMMER COMMON
- YV2** HEAT VALVE
- I** MINIMUM SPEED (red)
- II** MEDIUM SPEED (blue)
- III** MAXIMUM SPEED (black)
- T1** AUTOTRANSFORMER (excluded VCE 80-90-100 model)
- Com I** WINTER COMMON
- ST1** WATER LOW TEMPERATURE THERMOSTAT
- YV3** COOL VALVE

Electrical supply	230 ±10%V/1/50-60Hz
Max power dissipated	1VA
Feeler	PTC
Outlet	Relay 6 A, 250 V
Intervention differential	0,5°C
Settings	OFF-summer-winter / 3 speeds
Set point adjustment	6-30°C
Temperature limits	0-50°C
Humidity limits	10-90%U.R.
Container	ABS IP30
Dimensions	135 x 65 x 30 mm
Weight	130 g

4.5 ELECTRONIC THERMOSTAT WITH 3 SPEED CONTROL CD2/X4

By means of 2 switches, allow the remote control of a 3 speed fan coil. A switch selects the function OFF-ON-Manual while the other selects one of the three speed. The switch selects one of the two functions:

- **ON**: start of the motor and consensus to the valve when the temperature rises/decreases; (*by means of an external switch for the heat/cool selection - care of client*)

- **MANUAL**: consensus to the valve when the temperature rises/decreases and motor continuous running.

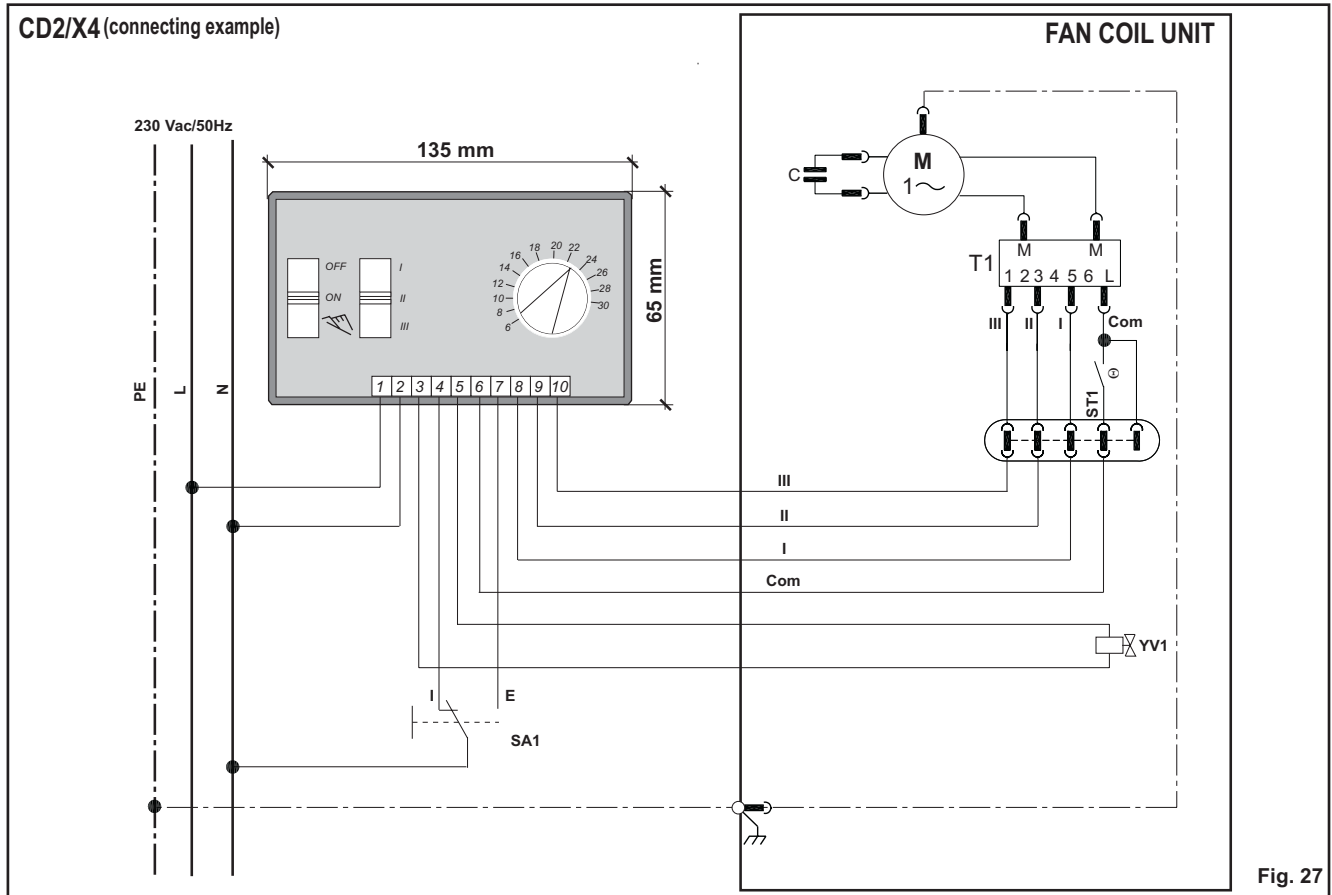

16

LEGEND:

PE PROTECTIVE CONDUCTOR (yellow/green)
N NEUTRAL
L PHASE
M FAN MOTOR
I WINTER
Com COMMON (white)
YV1 HEAT/COOL VALVE

I MINIMUM SPEED (red)
II MEDIUM SPEED (blue)
III MAXIMUM SPEED (black)
T1 AUTOTRANSFORMER (excluded VCE 80-90-100 model)
E SUMMER
ST1 WATER LOW TEMPERATURE THERMOSTAT
SA1 2 WAYS SWITCH (WINTER/SUMMER)

Electrical supply	230 ±10%V/1/50-60Hz
Max power dissipated	1VA
Outlet	Relay 6 A, 250 V
Intervention differential	0,5°C
Settings	OFF-ON-MANUAL - 3 speeds
Set point adjustment	6-30°C
Temperature limits	0-50°C
Humidity limits	10-90%U.R.
Container	ABS IP30
Dimensions	135 x 65 x 30 mm
Weight	160 g

4.6 ELECTRONIC THERMOSTAT WITH 3 SPEED CONTROL CD3/V AND CD3/N

The electronic thermostat CD3 foresees the change over OFF/summer/winter. It selects automatically one of the three speeds according to the temperature measured in the room.

The intervention differential between the 1st and the 2nd speed and between the 2nd and the 3rd speed can be selected by means of removable bridges.

The control can be required or with 3"1/2 display (CD3/V) to visualize the room temperature or without (CD3/N).

NOTE: IT IS NOT POSSIBLE TO CONNECT THE CD3 WITH AN APPARATUS THAT FORESEES THE WATER LOW TEMPERATURE THERMOSTAT!

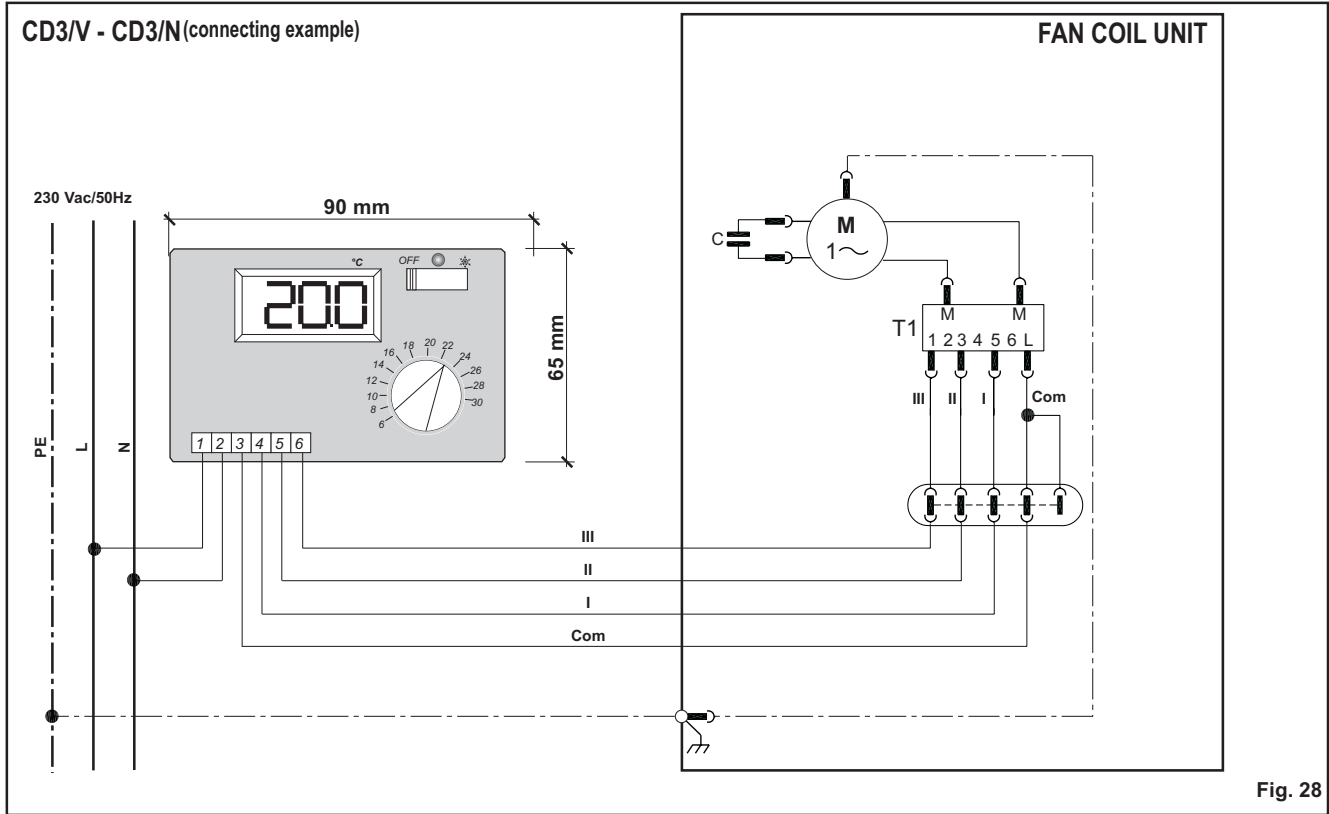

Fig. 28

LEGEND:

- PE** PROTECTIVE CONDUCTOR (yellow/green)
- N** NEUTRAL
- L** PHASE
- M** FAN MOTOR

- I** MINIMUM SPEED (red)
- II** MEDIUM SPEED (blue)
- III** MAXIMUM SPEED (black)
- Com** COMMON (white)

Electrical supply	230 ±10%V/1/50-60Hz
Max power dissipated	1VA
Feeler	PTC
Outlet	Relay 6 A, 250 V
Intervention differential	0,3°C
Settings	OFF-summer-winter
Set point adjustment	6-30°C
Resolution	0,1°C
Temperature limits	0-50°C
Humidity limits	10-90%U.R.
Signals	Red led
Display	Liquid crystal 3"1/2
Container	ABS IP30
Dimensions	90 x 65 x 30 mm
Weight	100 g

4.7 ELECTRONIC THERMOSTAT WITH 3 SPEED CONTROL CDR

It permits, by means of three switches, the remote control of a three speeds fan coil and an electric heater. A switch selects the function OFF-summer-winter, the other selects one of the three speeds and the third one OFF/RES actions the electric heater. The actioning of the valve is given both in the summer function as well in the winter function, while the consensus to the heater is given only in the winter function.

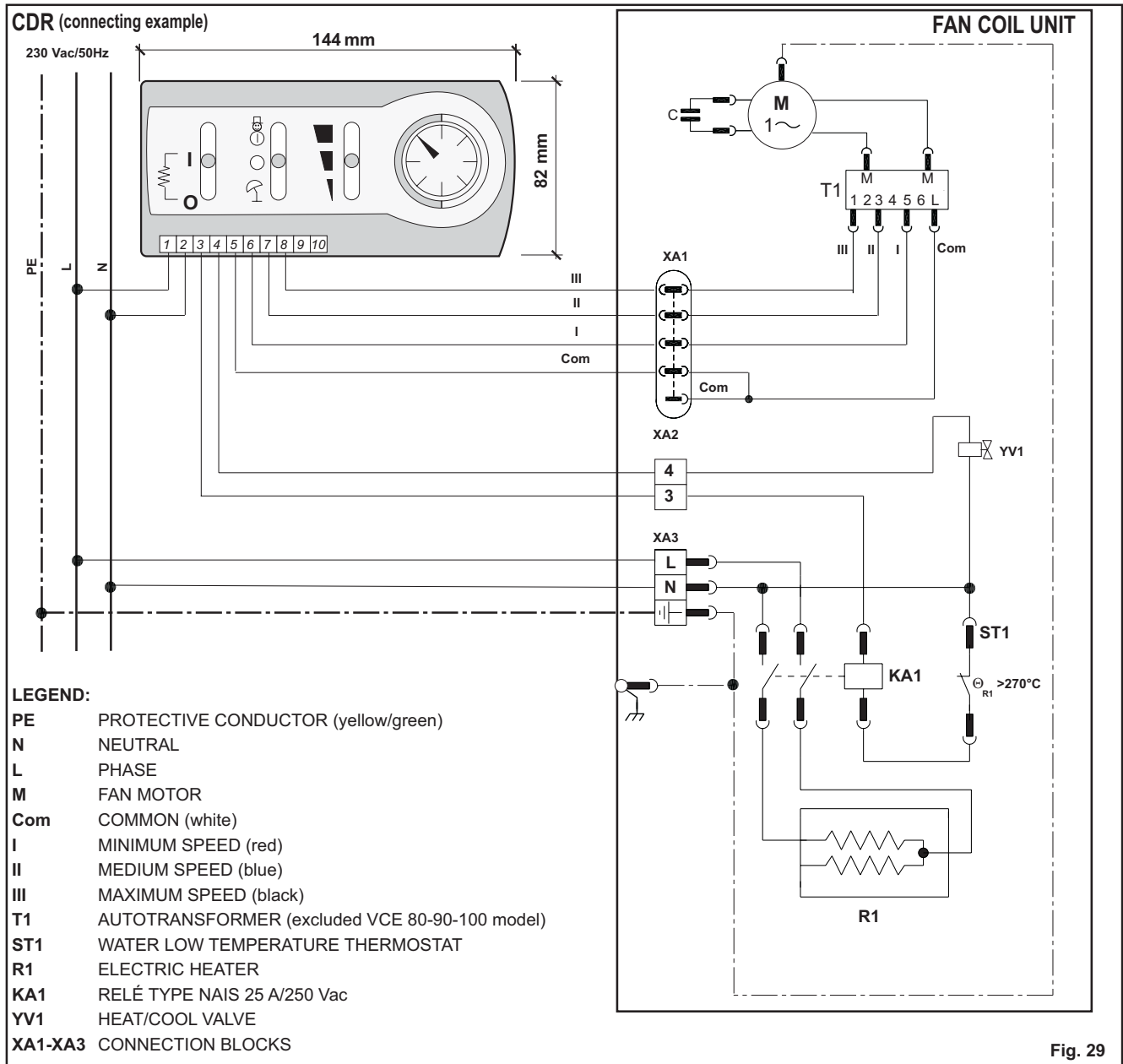

18

Electrical supply	24/230 Vac $\pm 10\%$ V/1/50-60Hz
Max power dissipated	1VA
Feeler	Thermoresistor NTC type
Outlet	Relay 8 A, SPDT 24/230 Vac
Intervention differential	0,5°C
Settings	OFF-summer-winter / 3 speeds / OFF-RES
Set point adjustment	5-30°C
Temperature limits	0-40°C
Humidity limits	10-90%U.R.
Container	ABS IP30
Dimensions	144 x 82 x 27 mm
Weight	170 g

4.8 ELECTRONIC THERMOSTAT WITH 3 SPEED CONTROL CD2/ZN

It permits, by means of two switches, the remote control of a three speeds fan coil. A switch selects the function OFF-ON while the other selects one of the three speeds. In ON function the motor always on while the thermostat activates automatically the heat and cool valve. A neutral zone adjustable from 1°C to 11°C is foreseen between the summer function and the winter function.

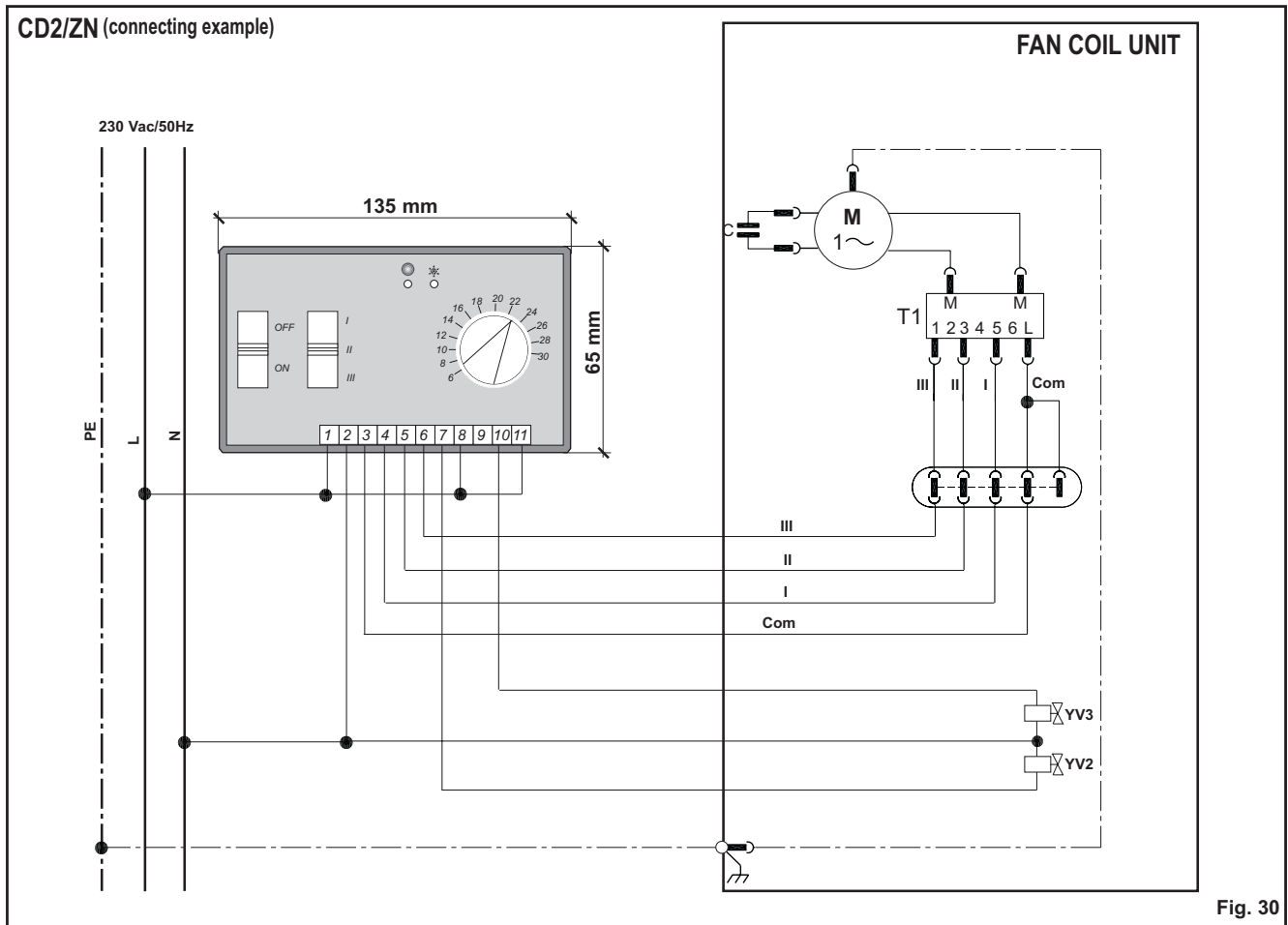

Fig. 30

LEGEND:

- PE PROTECTIVE CONDUCTOR (yellow/green)
- N NEUTRAL
- L PHASE
- M FAN MOTOR
- Com COMMON (white)
- YV3 COOL VALVE
- I MINIMUM SPEED (red)
- II MEDIUM SPEED (blue)
- III MAXIMUM SPEED (black)
- T1 AUTOTRANSFORMER (excluded VCE 80-90-100 model)
- YV2 HEAT VALVE

Electrical supply	230 ±10%V/1/50-60Hz
Max power dissipated	1VA
Feeler	PTC
Outlet	Relay 6 A, 250 V
Intervention differential	0,5°C
Settings	OFF-summer-winter / 3 speeds
Set point adjustment	6-30°C
Temperature limits	0-50°C
Humidity limits	10-90%U.R.
Container	ABS IP30
Dimensions	135 x 65 x 30 mm
Weight	160 g

4.9 INTERFACE CHART FOR THE CONTROL OF 4 FAN COIL MOD. SDI

By means of the interface chart (to be mounted on DIN bars) it is possible to control up to 4 fan coils with only one thermostat or remote control.

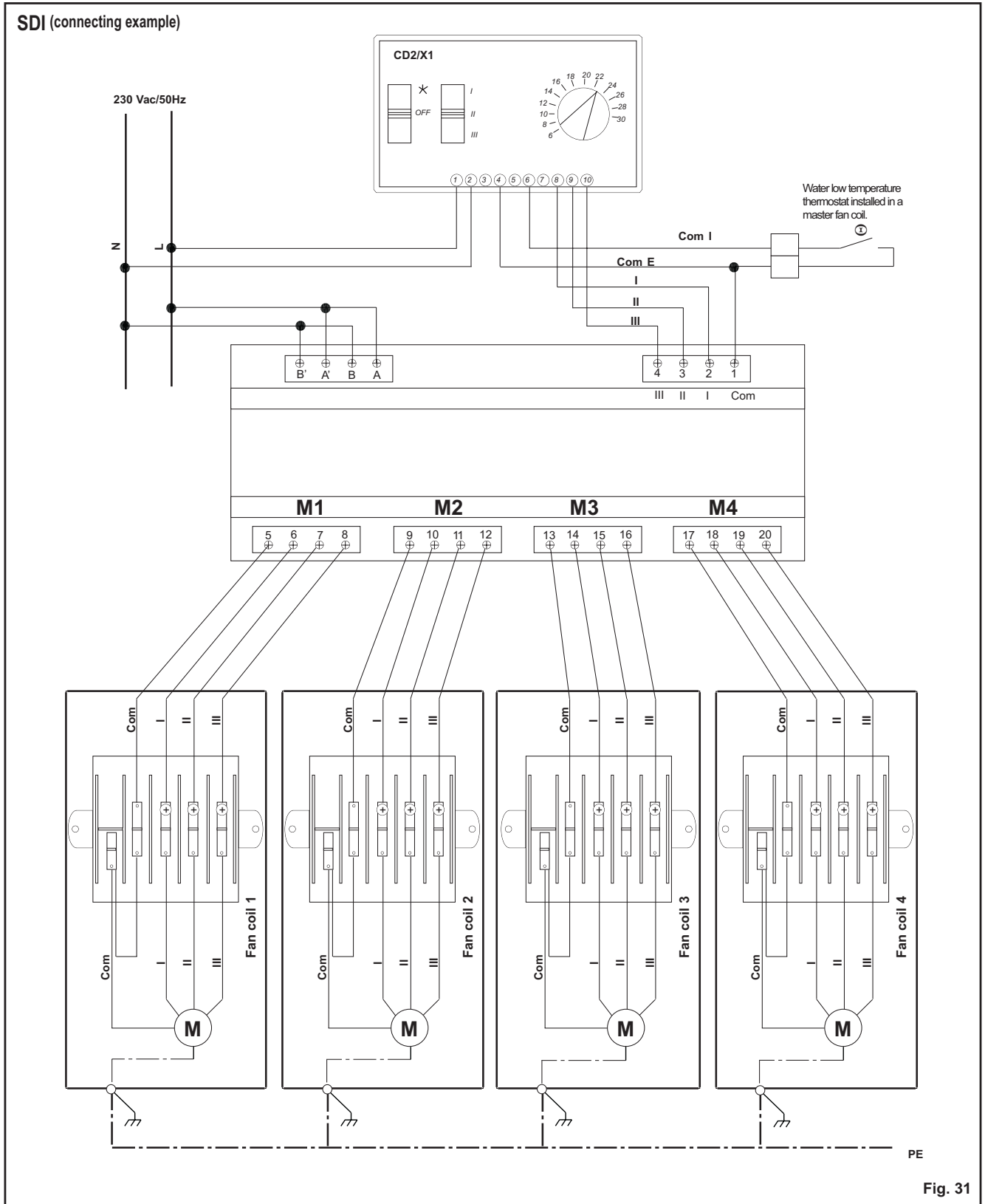

20

NOTE

Dotted lines for notes.

22

NOTE

Dotted lines for handwritten notes.

All the electric wirings shown in this manual are subject to updatings. We suggest to refer to the electric wiring enclosed with every fan coil. We reproduced the most common electric diagrams and controls. For eventual additional needs refer to our technical/commercial office.

Ventilclima takes part in EUROVENT CERTIFICATION program.
All products included in EUROVENT DIRECTORY



VENTILCLIMA S.p.A.
31020 SAN ZENONE DEGLI EZZELINI (TV) - Italy - Via Montegrappa, 67
Tel. (0039) 0423/969037 r.a. - Telefax (0039) 0423/968197
http: www.ventilclima.com - e-mail: info@ventilclima.com



ISO 9001:2000- Cert. n. 1368/1

CENTRIFUGAL FAN COIL UNITS

ME VCE 10120 0604 VENTILCLIMA GB