

serie
UTC

» INSTALLATION, USE AND
» MAINTENANCE GUIDE

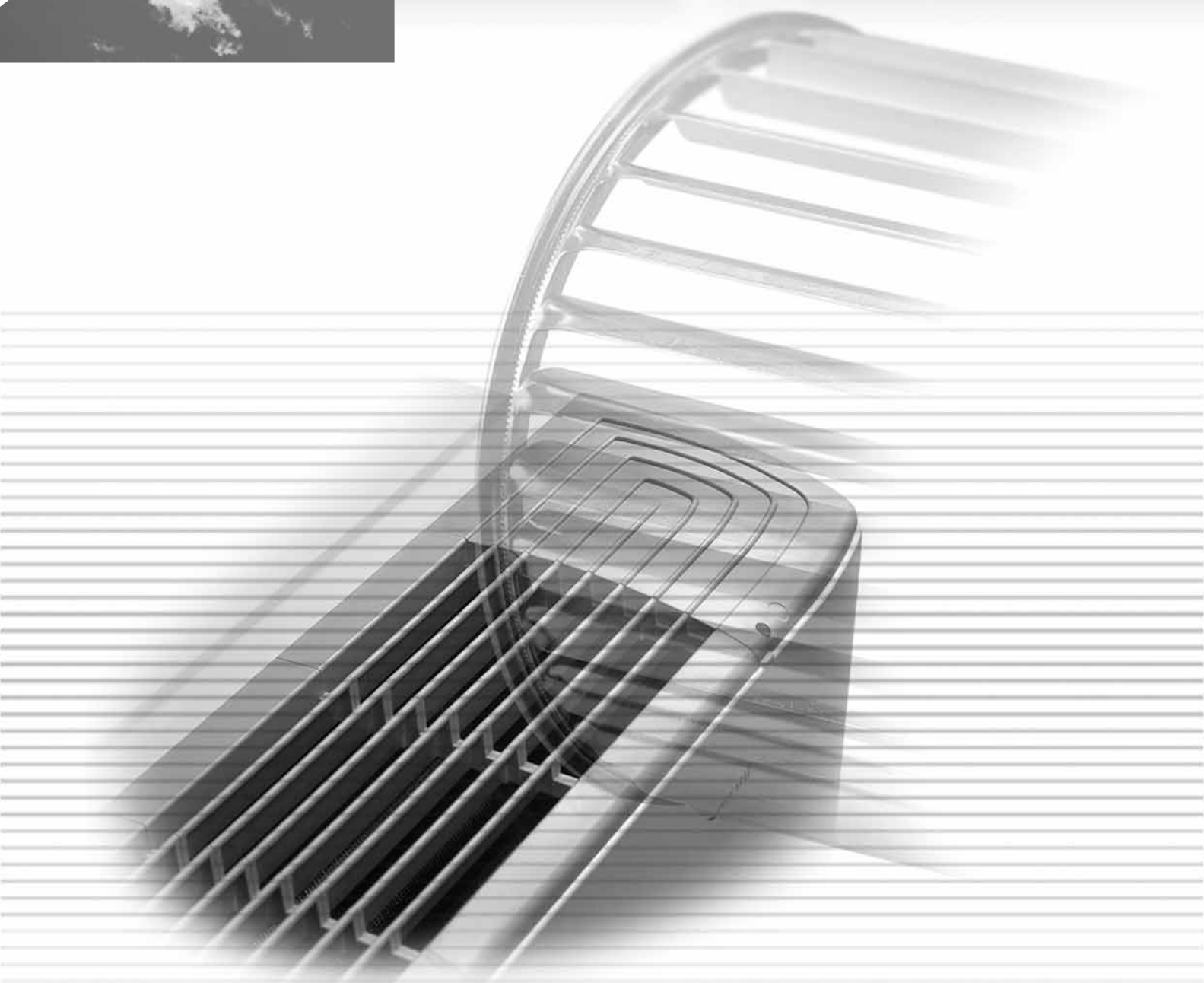

ISO9001:2000 - Cert. n. 1368/1



ventilclima®
Apparecchi per la Climatizzazione

DUCTABLE AIR TREATMENT UNITS

MI UTC 1105-0 VEN GB

INDEX

INTRODUCTION

RECOMMENDATIONS

FIRST PART: FOR THE INSTALLER

IDENTIFICATION OF THE UNIT

TRANSPORTATION, RECEIVING, HANDLING

Safety provisions

DESCRIPTION OF THE UNIT

General size of the base unit

General size of the accessories

General technical data

UNIT INSTALLATION

Recommendations for installation

Installation of the air treatment unit

Installation of the accessories

WATER CONNECTIONS

Connection to the trunk line

Condensate water drainage

ELECTRICAL CONNECTIONS

Recommendations

Connections to the terminal blocks: UTC 10-40

Connections to the terminal blocks: UTC 50

Connections to the terminal blocks: UTC 60

Connections to the terminal blocks: UTC 70

TURNING THE COIL

SECOND PART: FOR THE USER

CLEANING AND MAINTENANCE

Routine maintenance

Cleaning the air filter

WHAT TO DO IF...

DISMANTLING THE UNIT

INTRODUCTION

This installation and maintenance booklet should always accompany the air treatment unit for ready consultation by the installer or user if necessary. The unit should be installed in compliance with the regulations in force in each country and according to the manufacturer's or qualified person's instructions. The manufacturer cannot be held liable for any damage to property or injury to persons and animals caused by incorrect installation of the unit. Only qualified persons should install the unit and connect it to the mains electricity supply. Before carrying out any work on the unit, ensure that it is disconnected from the electricity supply. Read this instruction booklet prior to installation.

RECOMMENDATIONS

This unit is easy to use, but it is important to read all the contents of this guide before using it for the first time. This will help you to:

- **use the unit in all safety**
- **obtain best performance**
- **avoid incorrect actions**
- **respect the environment**
- Do not allow children or unassisted handicapped persons to use the unit.
- Do not touch the unit with wet parts of the body or if barefoot.
- Do not tug, pull or twist electrical cables attached to the unit, even when disconnected from the electricity supply.
- Do not open the flaps giving access to the internal parts of the unit without having first put the system on-off switch to "off".
- Do not introduce sharp pointed objects through the air intake and outlet grilles.
- Do not leave packing material (boards, staples, plastic bags, etc.) within reach of children since they could be a source of danger. Dispose of correctly.
- Do not spray or throw water directly on the unit.
- Do not use the unit in places with suspended dust/powder or in potentially explosive atmospheres, in very damp environments or in the presence of oil in suspension or in particularly aggressive atmospheres.
- Do not cover the unit with objects or drapes that even partially obstruct the air flow.

The unit works by electricity at mains voltage (230 Vac, 50 Hz). Always bear in mind that mains voltage is potentially dangerous and any appliance connected to it should be used with caution. Before carrying out any work on the unit, disconnect it from the electricity supply (by pulling out the plug from the mains socket or isolating the supply line by putting the on-off switch OFF. If the unit is not be used for long periods, make sure that the controls

are in the position 0 (off). If the unit is not going to be used in winter when temperatures are near to freezing, drain the system and ensure that the unit heat exchanger has no water in it in order to prevent the formation of ice and consequent breakage. To make the unit inoperable, disconnect it totally from the electricity supply. It is unsafe to alter or try to alter the characteristics of this product. Any tampering or alteration in any case makes the warranty null and void. In the event of malfunction or failure, do not try to repair the unit yourself; contact a qualified technician. Repairs carried out by incompetent persons could cause damage or accidents. Always keep the unit clean. In particular clean the air filter periodically (at least once a month).

⚠ FAILURE TO COMPLY WITH THE ASSEMBLY INSTRUCTIONS GIVEN IN THIS GUIDE RELIEVES THE PRODUCER OF ALL AND ANY LIABILITY. INCORRECT INSTALLATION COULD CAUSE MALFUNCTIONING OR FAILURE OF THE UNIT. IT COULD ALSO REPRESENT A HAZARD FOR THE USER

IDENTIFICATION OF THE UNIT

The air treatment units come with a rating plate, which shows:

- The manufacturer's address
- Supply voltage in "V"
- "CE" marking
- Supply frequency in "Hz"
- Model
- Input in "W"
- Lot number
- Total cooling capacity in "W"
- Date of production
- Sensible cooling capacity in "W"
- Rated absorbed current in "A"
- Heat output.
- Number of phases, indicated with "Ph"

TRANSPORTATION, RECEIVING, HANDLING

The units and their accessories are enclosed in cardboard boxes up to size 50, while the other sizes are palletised. The packs should be kept intact until positioned in the final place of installation. Use suitable handling equipment according to the weight of the unit, as provided for by directive 89/391/EEC and subsequent amendments. The weight of each single machine is given in this guide (table 2). Upon receiving the unit, check all the parts for any damage caused in transit. Any damage should be reported to the carrier by affixing an accepted with reservation on the accompanying note, specifying the type of damage. In the event of prolonged storage, keep the units protected against dust and far from sources of vibration or heat. The number of units that may be positioned on one pallet are given in the table (table 1).

⚠ THE PRODUCER CANNOT BE HELD LIABLE FOR DAMAGE DUE TO INCORRECT HANDLING OR LACK OF PROTECTION AGAINST THE ELEMENTS.

SAFETY PROVISIONS



- Secure packs during transportation.
- Do not expose to the elements.
- Do not tread on packs.
- Protect hands with work gloves when dismantling the unit.
- Work in PAIRS if the appliance weighs more than 25 kg.

MODEL	U.M.	UTC 10	UTC 20	UTC 30	UTC 40	UTC 50	UTC 60	UTC 70
Unit overall dim.	mm	650x533x299	1.000x533x299	1.100x533x324	1.339x533x324	1.339x533x374	1.341x853x674	2.028x853x674
Max. number per pallet	N.	10	5	5	5	5	2	2
Pallet size		140x80	120x80	120x80	150x80	150x80	150x100	230x100

N.B.: the units may be stacked up to a maximum of 1.80 m in height

Tab. 1

DESCRIPTION OF THE UNIT
GENERAL SIZE OF THE BASE UNIT

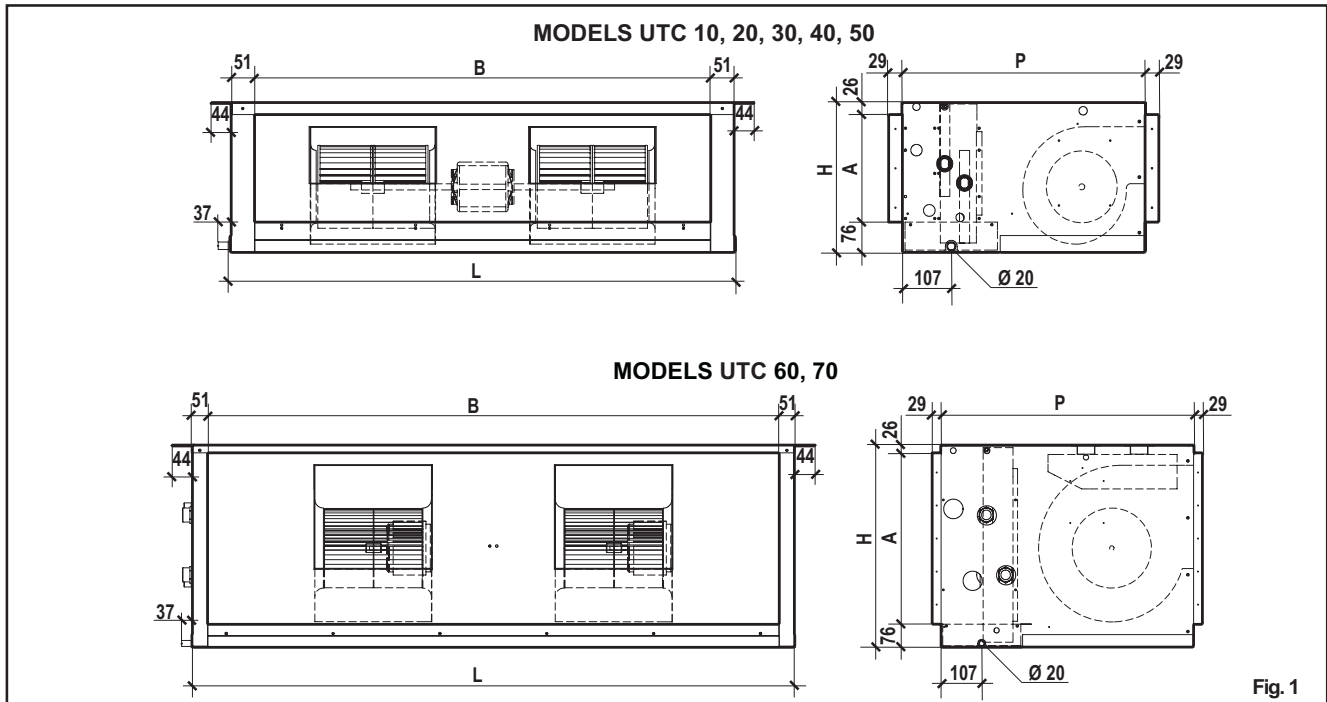

GENERAL SIZE OF DUCTWORK ACCESSORIES

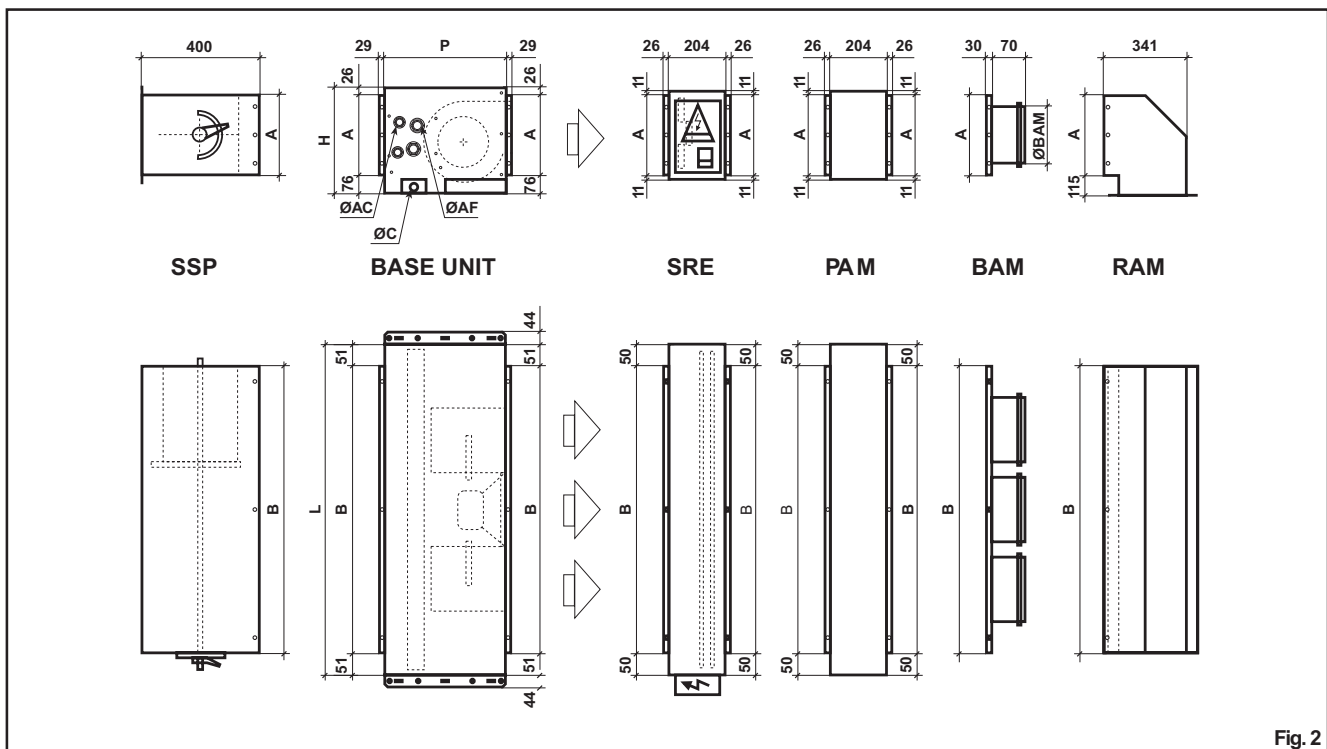

INSTALLATION/USE/MAINTENANCE GUIDE

GENERAL TECHNICAL DATA

MODELLO		UTC 10	UTC 20	UTC 30	UTC 40	UTC 50	UTC 60	UTC 70
Fans - Motors	No.	1-1	2-1	2-1	2-1	2-1	1-1	2-2
Standard coil	Rows	3	3	3	3	3	4	4
	Fittings (ØAF) Ø	1/2"	1/2"	3/4"	3/4"	1"	1"1/4"	1"1/2"
Auxiliary coil	Rows	1	1	1	1	1	2	2
	Fittings (ØAC) Ø	1/2"	1/2"	1/2"	1/2"	3/4"	1"	1"1/4"
Cond. drain fitting (ØC) Ø mm		20	20	20	20	20	20	20
High (H) mm		299	299	324	324	374	674	674
Length (L) mm		650	1.000	1.100	1.339	1.339	1.341	2.028
Depth (P) mm	(P)	533	533	533	533	533	853	853
	(A) mm	197	197	222	222	272	572	572
	(B) mm	548	898	998	1.237	1.237	1.239	1.926
N. x Ø BAM	mm	2xØ200	3xØ200	3xØ200	4xØ200	4xØ200	2xØ200	4xØ200
Net Weight	kg	28	26	41	46	57	117	192
Max. power motor input	W	162	218	322	340	582	1.320	2.600
Max. current motor input	A	0,72	0,97	1,43	1,51	2,58	5,86	11,54

Electrical supply: 230 V/1/50 Hz

Tab. 2

UNIT INSTALLATION RECOMMENDATIONS FOR INSTALLATION!

Before installing the unit, ensure that:

- 1) the place of installation has sufficient space for carrying out installation as well as routine and extraordinary maintenance work (see fig. 3). If the unit is installed behind a suspended ceiling, an access should be provided;
- 2) there are no obstructions for air intake and delivery;
- 3) the water fittings are of the sizes, in the position and spaced apart as required by the unit;
- 4) the system pressure does not exceed 8 bar for the water-filled versions;
- 5) the electricity supply corresponds to the data on the unit rating plate and that there is a circuit breaker switch readily accessible to the user to cut off the power supply whenever necessary;
- 6) the circuit breaker is in the OFF position so that there is no voltage on the unit supply line.

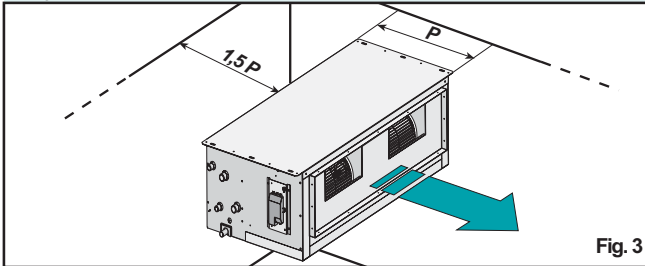

Fig. 3

INSTALLATION OF THE AIR TREATMENT UNIT

Preliminary operations:

- check that the various unit components are perfectly intact;
- check that the installation accessories and documentation are in the pack;
- place the packed section as close as possible to the place of installation;
- do not place tools or weights of any kind on the packed unit.

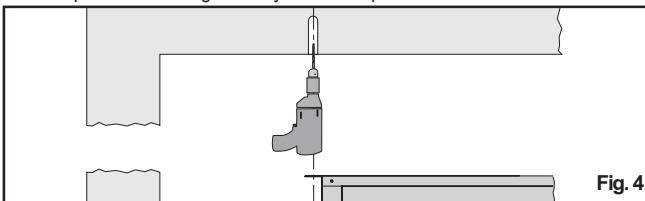

Fig. 4

Drill the holes in line with the relative slots for the 6 unit screw anchors (fig. 4). Inject thermosetting resin into the holes and then insert the screw anchors (fig. 5).

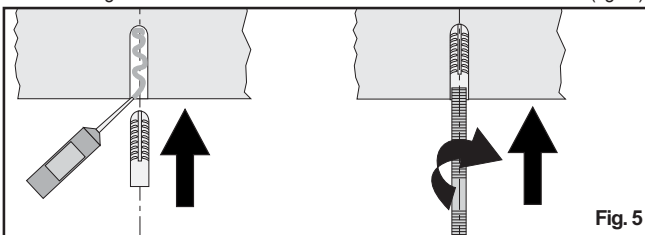

Fig. 5

Fix the threaded rods of the correct length to the screw anchors (fig. 5) and insert them into the relative slots (fig. 6). After having created a slope (max. 3 cm/m) in the direction of the condensate outlet, lock the threaded rod with a nut and check nut. To prevent

possible noise being created by vibrations from the unit, it is advisable to insert a vibration-damping joint.

N.B.: the screw anchors, threaded rods and whatever else is necessary for accomplishing the installation are **NOT** included in the supply of the air treatment unit.

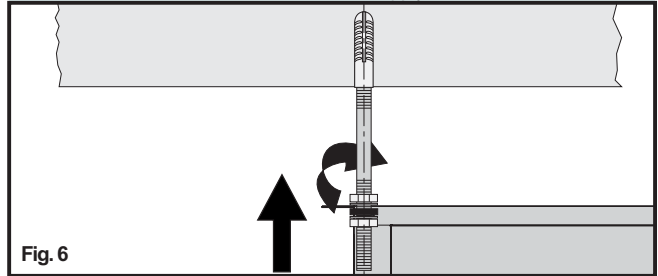

Fig. 6

INSTALLATION OF THE ACCESSORIES

Some examples are given below of assembling the accessories for ducted air treatment units.

Example 1

First of all put the air filter section (SFA) on the unit intake, inserting it into the special rim (male-female) and fixing it with the galvanised self-tapping screws 4.2x9.5. Proceed as described above on the delivery end with the connecting flange (FAM). Put the vibration isolation joint (GAM) on the flange and fix it using the cheese-headed screws M8x16 and hexagon bolts.

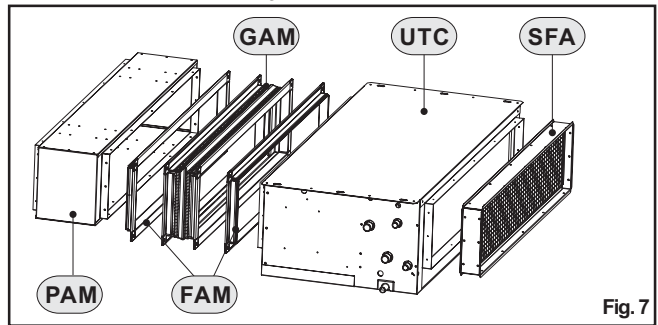

Fig. 7

Example 2

Proceed by inserting the manual air intake section (SSP) into the air filter section (SFA) by means of the male-female coupling. After having secured it with the self-tapping screws (4.2 x 9.5 galvanised), anchor it to the ceiling as illustrated for the base unit in figures 4-7. Put another connecting flange on the vibration isolation joint (GAM) and secure it using cheese-headed screws M8x16 and hexagon bolts. Insert the straight delivery plenum (PAM) in the connecting flange and fix it using galvanised self-tapping screws 4.2 x 9.5. Connect the air delivery union with round fittings (BAM) with the procedure described above.

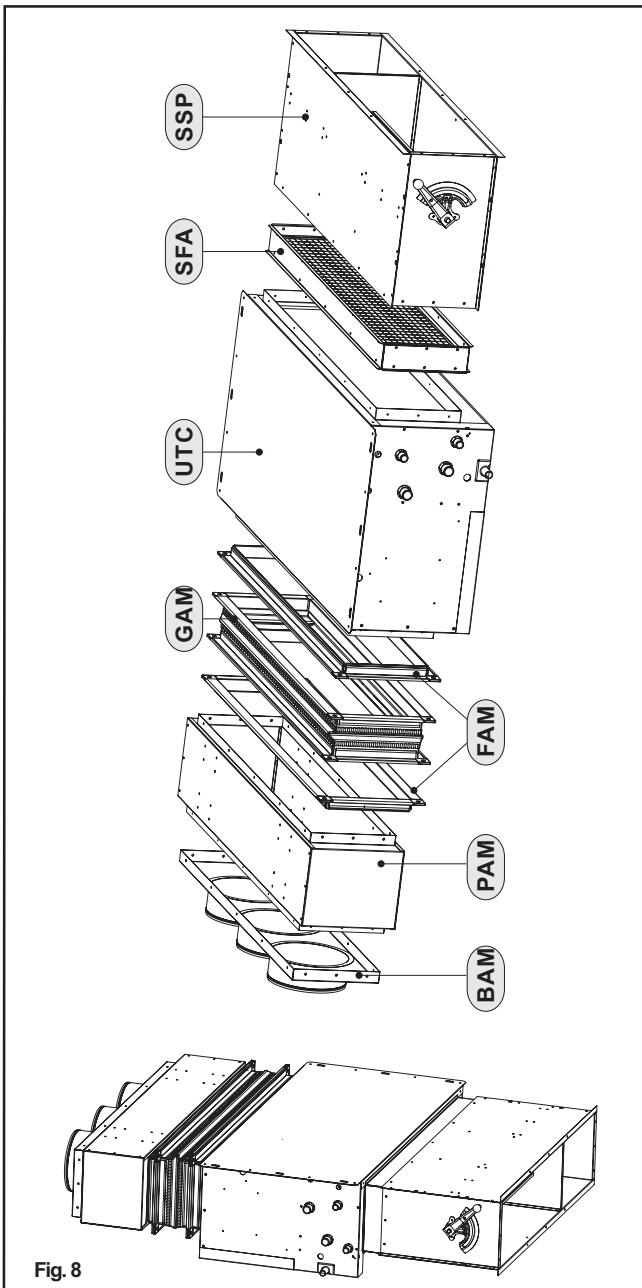

Fig. 8

Esempio 3

A 90° plenum (RAM) may be used instead of the air delivery union for better direction of airflow. Insert the manual air intake section (SSP) in the air filter section (SFA) by means of the male-female coupling. After having secured it with the self-tapping screws (4.2 x 9.5 galvanised), anchor it to the ceiling as illustrated for the base unit in figures 4-7. Put another connecting flange on the vibration isolation joint (GAM) and secure it using cheese-headed screws M8x16 and hexagon bolts. Insert the straight delivery plenum (PAM) in the connecting flange and fix it using galvanised self-tapping screws 4.2 x 9.5. Then connect the 90° plenum (RAM) with the procedure described above.

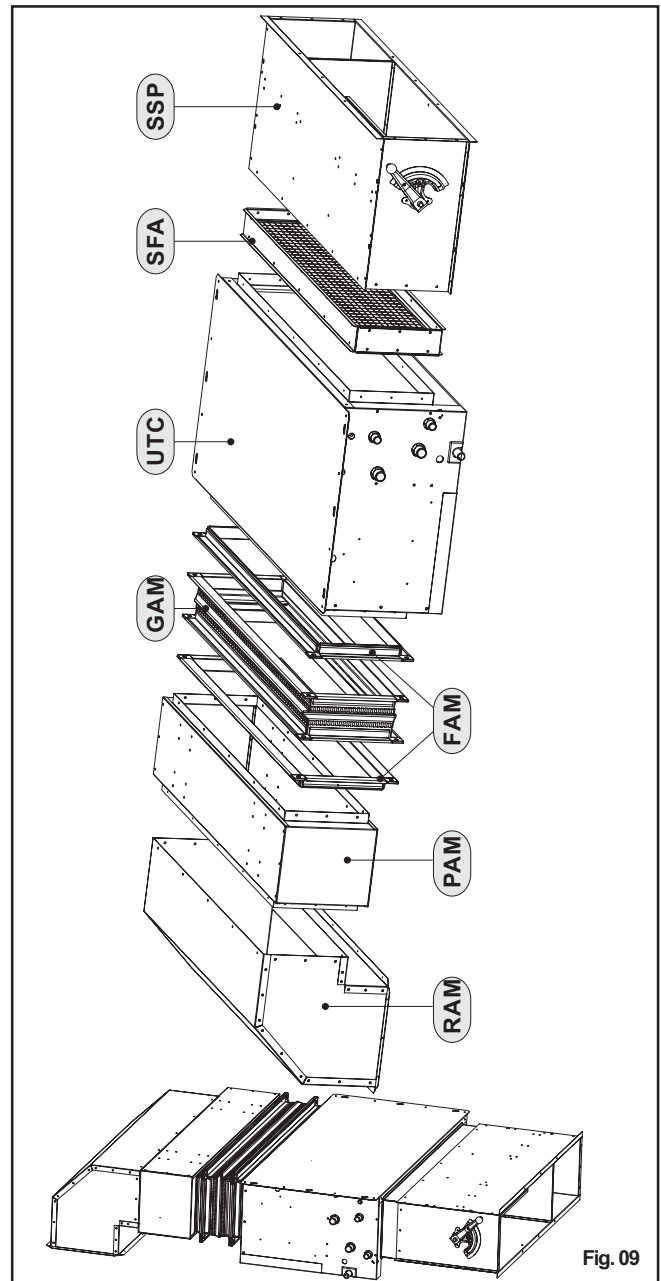

Fig. 09

Esempio 4

La sezione di riscaldamento con resistenza elettrica (SRE) viene di solito posizionata in mandata prima del plenum dritto di mandata (PAM). Può essere utilizzata indifferentemente con il bocchettone di mandata (BAM) o con il plenum a 90° di mandata (RAM). L'aggancio è di tipo maschio-femmina con fissaggio mediante viti autoforanti 4,2 x 9,5 zincate.

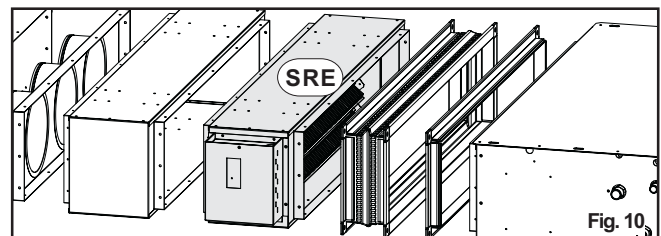

Fig. 10

INSTALLATION/USE/MAINTENANCE GUIDE

HYDRAULIC CONNECTION MAIN HYDRAULIC CONNECTION

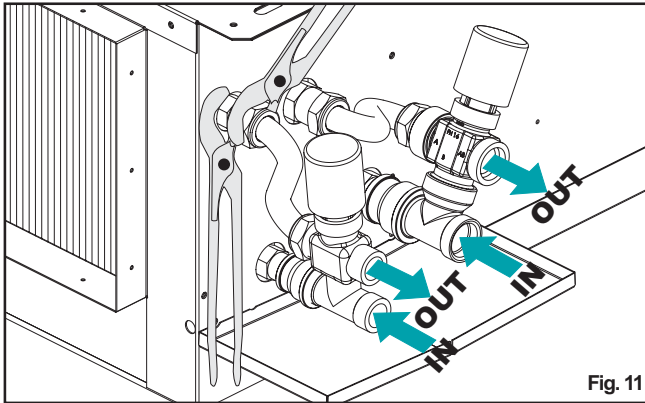

Fig. 11

CAUTION! Always use a wrench and counter-wrench for connection of the coil to the pipes (fig. 11).

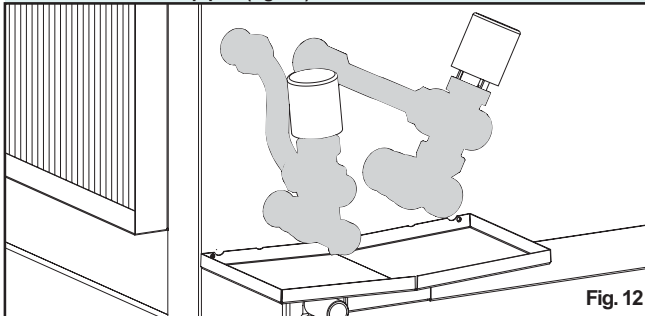

Fig. 12

CAUTION! If the valve is installed, suitably insulate the valve body with insulating material (fig. 12).

Connect the water inlet and outlet pipes, observing the indications given on the side of the unit. Correctly insulate the water supply pipes to prevent dripping during the cooling mode of operation. A shutoff valve should be inserted on the water supply pipe and a balancing valve on the outlet pipe. The valve body and balancing valve should also be properly insulated to prevent dripping. It is the installer's responsibility to insulate properly and the manufacturer cannot be held liable for any insulation work. **N.B.:** It is always advisable to install the valve. In the heating mode of operation the valve reduces consumption because upon reaching the set temperature the circulation of water is stopped to avoid wasting energy (the fan coil would otherwise continue to heat like a radiator, even with the motor at a standstill). **In the cooling mode of operation the valve stops the circulation of water when the set temperature is reached, this stopping the internal exchanger from continuing to condense water with possible undesirable dripping onto the floor. It also reduces chiller operation with consequent energy saving.**

WIRING DIAGRAM UTC MOD. 10 - 20 - 30 - 40

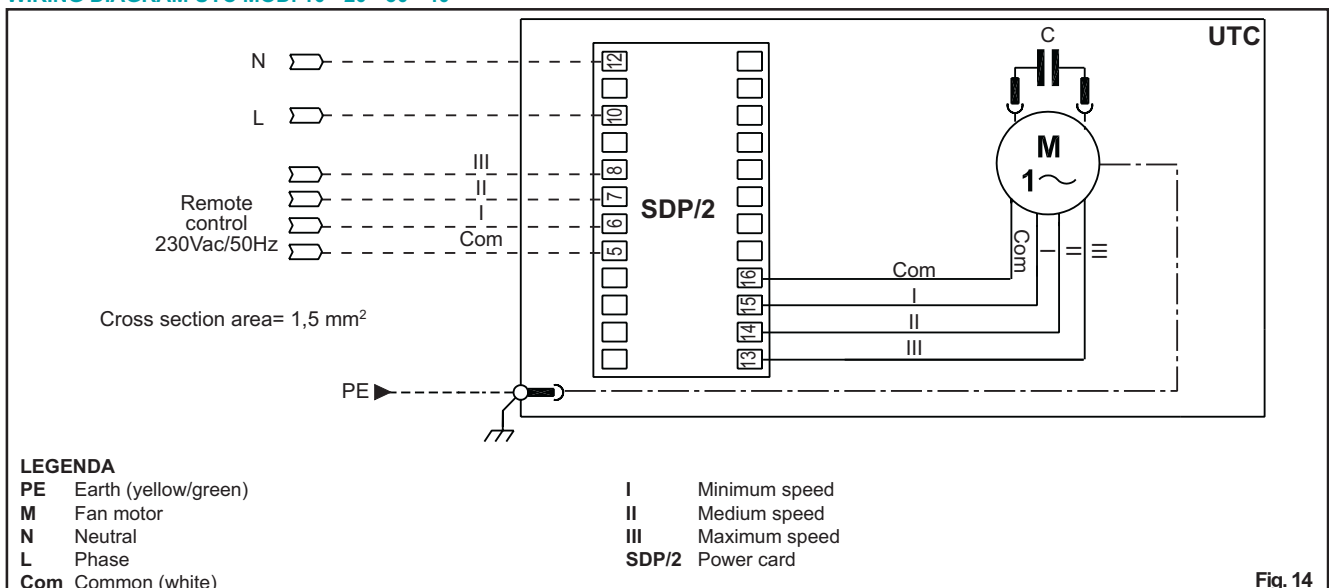

Fig. 14

CONDENSATE WATER DRAINAGE

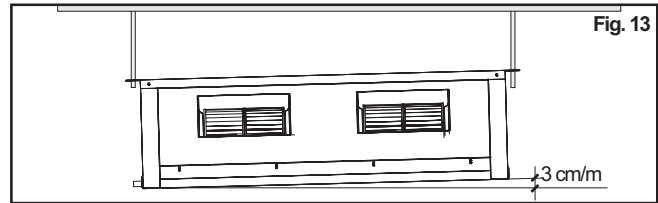

Fig. 13

The condensate drain pipe should slope downwards by at least 3 cm/m and should not have ascending or throttled sections in order to ensure a regular flow of water. It is advisable for a trap to be fitted. The condensate drain pipe should be connected to a rainwater drainage system. Do not use sewage systems to avoid possible rising of odours in the event of evaporation of the water in the trap. Upon completion of work, check that the condensate flows out properly by pouring water into the tray. The condensate water drainage system should be fabricated in a workmanlike manner and should be periodically checked. **The manufacturer cannot be held liable for any damage caused by dripping in the absence of a valve or of periodic maintenance of the drainage system.**

ELECTRICAL CONNECTIONS

RECOMMENDATIONS

- Before carrying out electrical connections, ensure that the electricity supply to the supply line has been cut off, checking that the on-off switch is in the OFF position.
- Only qualified electricians should carry out the electrical connections.
 - Check that the mains supply is single-phase 230 Vac/1/50 Hz ($\pm 10\%$).
 - Operating the unit with voltages outside the above limits could cause malfunction and renders the warranty null and void.
 - The power supply line should be fitted with at least a switch isolator in conformity with European standard EN60947-3.
 - Make sure that the electrical system is suitable for providing not only the working current required by the unit, but also the necessary current for powering household and other electrical appliances already in use. Any electrical and mechanical alterations or tampering render the warranty null and void.

The cables should be sufficiently long so that they are not permanently taut or create throttling or compression on metal parts.

The power cables should be sufficiently long so that in the event of accidental tugging the active wires are subjected to stress before the earth wire. Connect the earth wire to the relative terminal marked with the symbol \perp . Comply with the safety regulations in force in the country of installation.

CONNECTIONS TO THE TERMINAL BOARDS

The electrical connections should be made to the terminal boards on the side of the appliance. Each terminal is identified by the label to be found on the terminal boards.

CAUTION! FAILURE TO COMPLY WITH THE INDICATED CONNECTIONS MAY CAUSE MOTOR BURNOUT!

WIRING DIAGRAM UTC MOD. 50

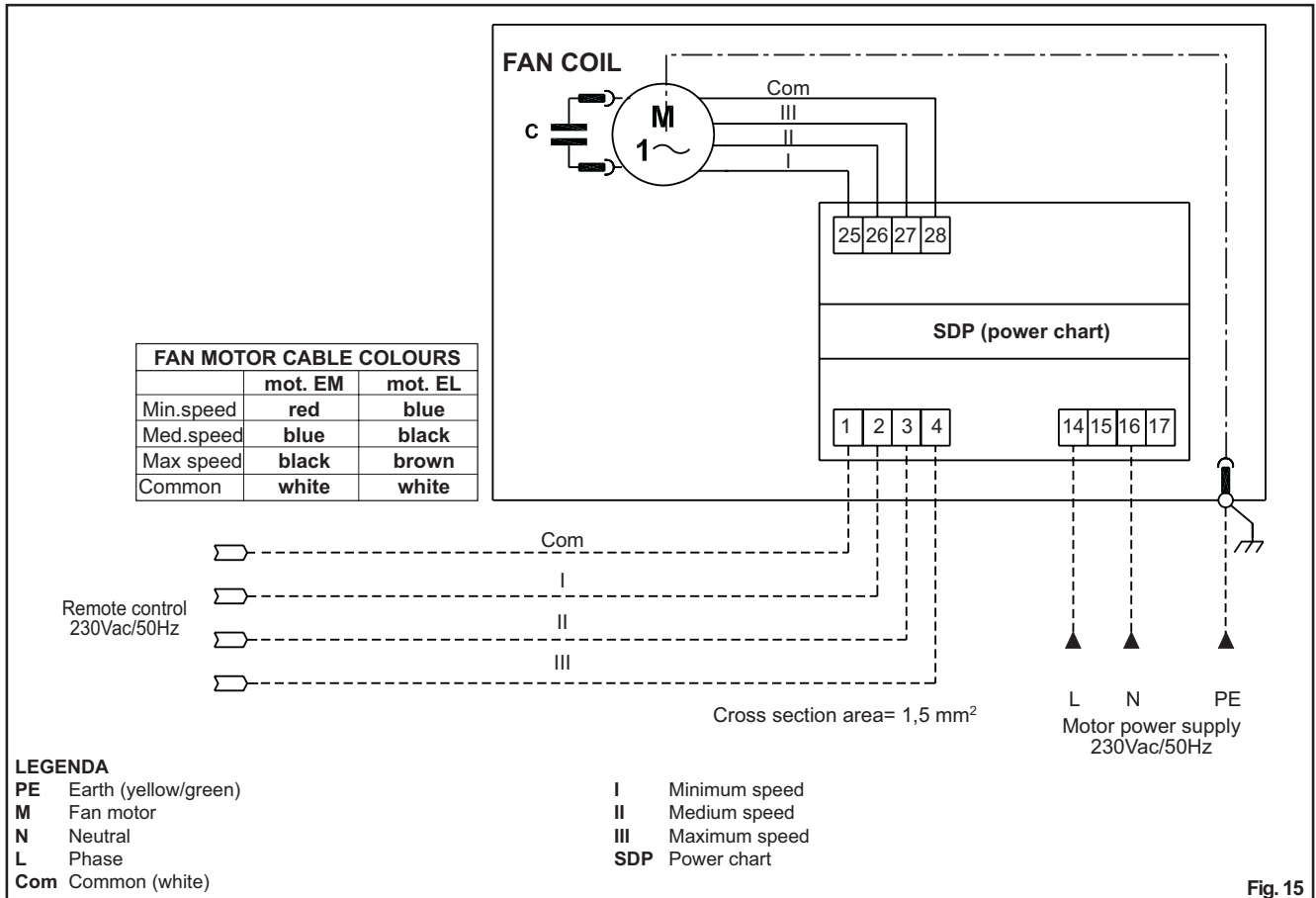

WIRING DIAGRAM UTC MOD. 60

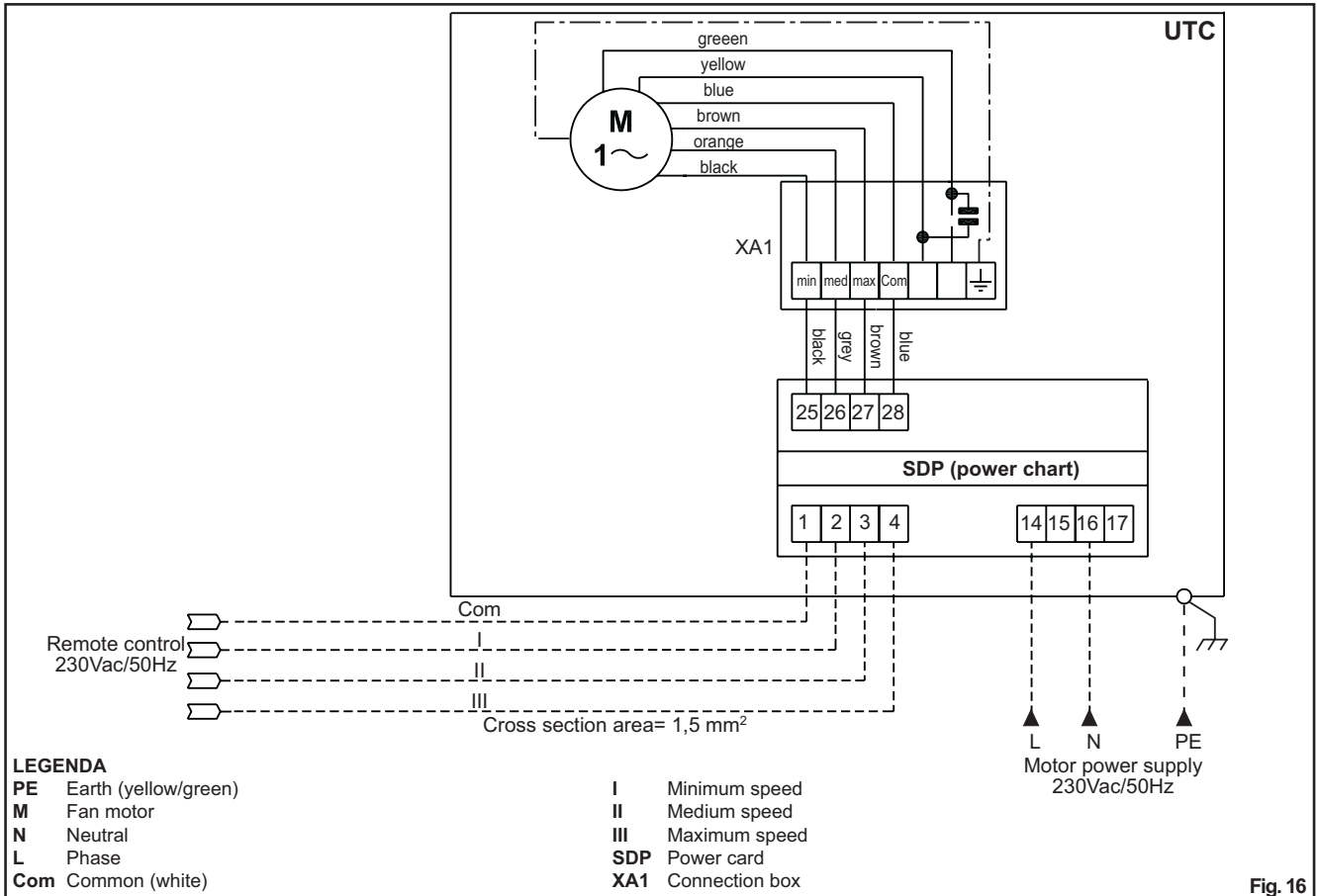

INSTALLATION/USE/MAINTENANCE GUIDE

WIRING DIAGRAM UTC MOD. 70

INSTALLATION/USE/MAINTENANCE GUIDE

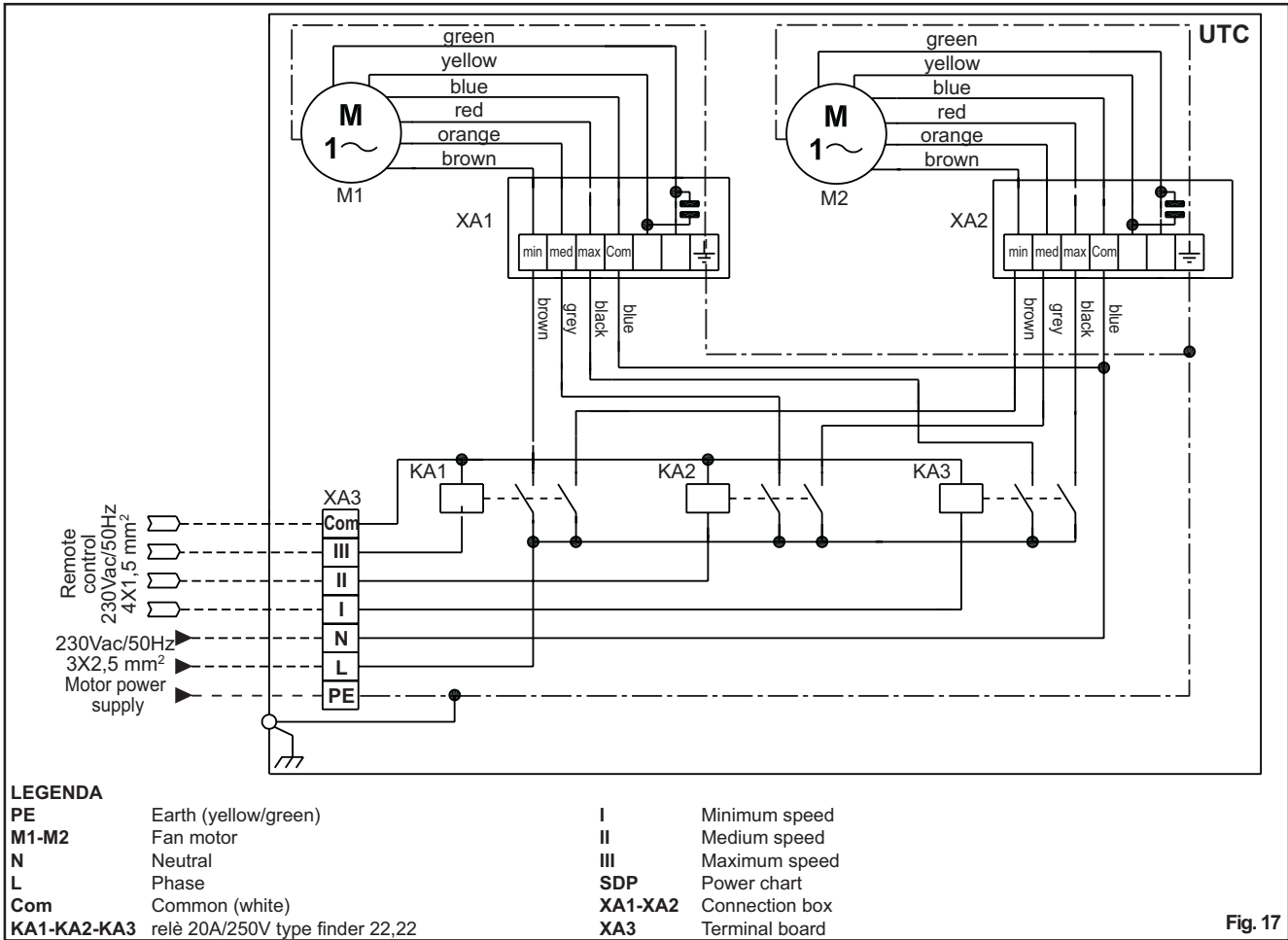

Fig. 17

TURNING THE COIL
⚠ CAUTION

The fan wheels may reach the speed of 1,000 rpm. Do not insert objects into the electric fan and certainly not hands. The motor becomes hot during operation; wait for it to cool before touching it. During the heating mode of operation the exchanger and the connecting pipes may become very hot (80°C). Wait for the exchanger to cool before touching it or protect hands with suitable gloves. The heat exchange water coils are suitable for working up to a maximum pressure of 8 bar.

To turn the coil, proceed as follows:

1. Disconnect the terminal board (6) from the side of the unit.
2. Remove the condensate collecting tray (2).
3. Remove the coil fixing screws (5).
4. Take out the coil (3), being careful not to be cut by the fins and not to damage them.
5. Remove the knockouts (1) on the opposite side of the unit (using a screwdriver) to allow the coil connections to pass through.
6. Position the coil, turning it without tipping it upside down, so that the fittings are in line with the holes left by the knockouts.
7. Fix the coil using the previously removed screws (5).
8. Shift the terminal board (fixing it to the side opposite the water fittings) and the motor cables, fixing them with their clamps. Ensure that the cables pass through the hole in the side of the unit, protecting them with the relative grommet. If it proves easier to carry out this operation by separating the wires from the terminal board, mark the positions of the wires to avoid making mistakes when reconnecting.
9. Reconnect the wires to the relative terminal board (6), taking care that they are correctly positioned.
10. Replace the condensate collecting tray (2).

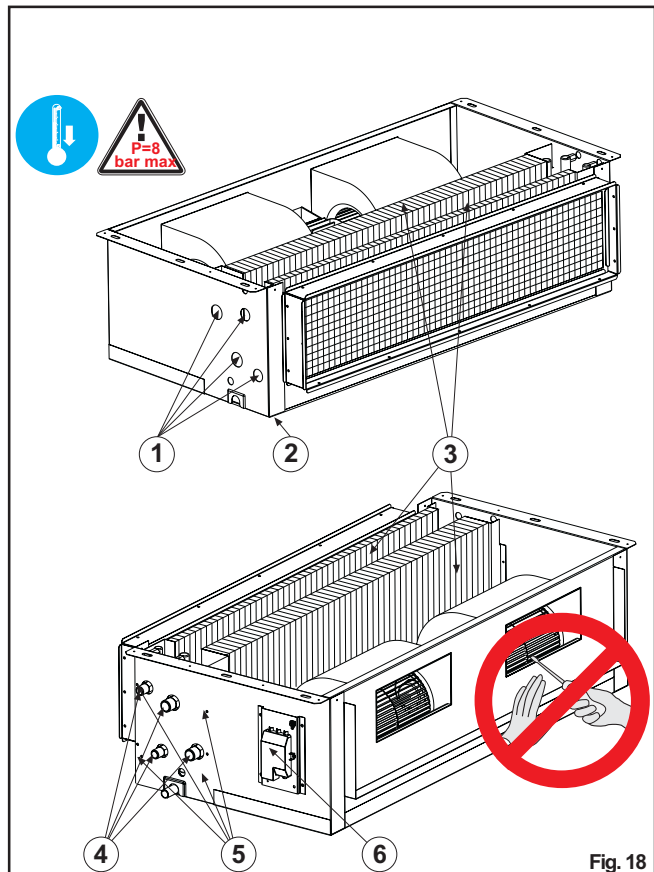

Fig. 18

CLEANING AND MAINTENANCE

CAUTION! Before carrying out any cleaning or maintenance work, disconnect the unit from the mains electricity supply!

ROUTINE MAINTENANCE

The user is duty bound to have all maintenance operations carried out by trained and qualified personnel only. If the unit has to be dismantled, protect hands with work gloves.

Monthly checks:

- Ensure that the fan impellers are clean. If they are dirty, clean them by suction so as not to damage them.
- Check the whole of the electrical part and in particular that the electrical connections are tight.

Yearly checks:

- Check the whole of the electrical part and in particular that the electrical connections are tight.
- Check the tightness of all the bolts, nuts and whatever else may be loosened by the constant vibrations of the unit.
- Check the motor for dust, dirt or other impurities. Periodically check that the motor works without unusual vibrations or noise and that the fan inlet is not obstructed, which could otherwise lead to overheating of the windings.
- Check the fans for dirt or any foreign matter.

CLEANING THE AIR FILTER

The unit is fitted with an air filter on the fan inlet. During normal operation the filter holds back impurities in the air.

The filter should be cleaned periodically to keep its filtering properties and the airflow to the fan unchanged.

It is advisable to clean the filter at least once a month, proceeding as follows.

1. Take out the filter.
2. Place the filter on a flat, dry surface and remove the accumulated dust with a vacuum cleaner.
3. Wash the filter with water and detergent (no solvents).
4. Leave the filter to dry in a ventilated place in the sun.
5. Replace the filter when it is perfectly dry.

Please clean the air filter every working season of the unit or more frequently considering the unit activity.

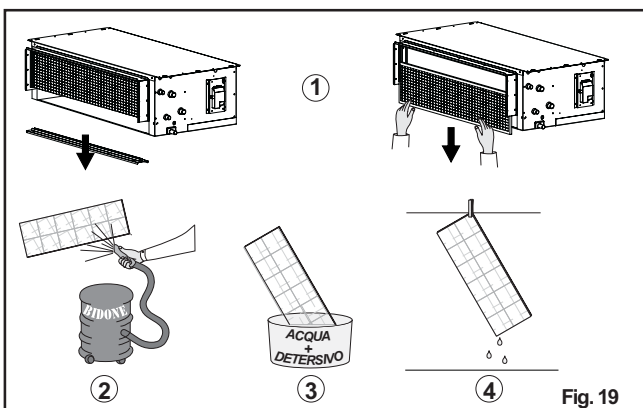

N.B.: the filter may also be taken out from the side or from the top.
WHAT TO DO IF...

There is little outflowing air?

- Incorrect speed setting on the control panel (select the right speed).
- Clogged filter (clean the filter)
- Obstruction of the airflow on the intake or delivery line (remove obstruction).

The motor does not turn? Check that...

- The power supply is switched on;
- The switches or thermostats are in the correct operating position;
- There is no foreign matter jamming the rotation of the fan.

The unit does not heat/cool as before? Check that...

- The filter and the coil are clean;
- No air has entered the water circuit by bleeding from the relative valve;
- The installation is correctly balanced;
- The boiler/chiller is in proper working order.

DISMANTLING THE UNIT

This unit is made to last for many years. Qualified personnel are needed to dismantle it in all safety. The first operation to be carried out before dismantling the unit is to disconnect it once and for all from the electricity supply.

This unit has been made using recyclable materials (copper, aluminium, brass, plastic) and assembled by screws and push-fits to make separation of the parts easy.

Contact a firm specialised in differentiated waste disposal; it is the only way to be certain of correct recycling and thereby contribute to protection of the environment.





ISO 9001:2000 - Cert. n. 1368/1

INSTALLATION/USE/MAINTENANCE GUIDE

All datas in this manual are no-binding for Ventilclima company who takes the right without advance notice obligation, to provide to any modification for product improvements.

Ventilclima takes part in **EUROVENT CERTIFICATION** program. All products included in **EUROVENT** Directory



VENTILCLIMA S.p.A.
31020 SAN ZENONE DEGLI EZZELINI (TV) - Italy - Via Montegrappa, 67
Tel. +39 (0) 423 969037 r.a. - Telefax +39 (0) 423 968197
[http: www.ventilclima.com](http://www.ventilclima.com) - e-mail: info@ventilclima.com



ISO9001:2000 - Cert. n. 1368/1