

# THE COOLING TOWER COLLECTION

*QUALITY – EFFICIENCY – HYGIENE*

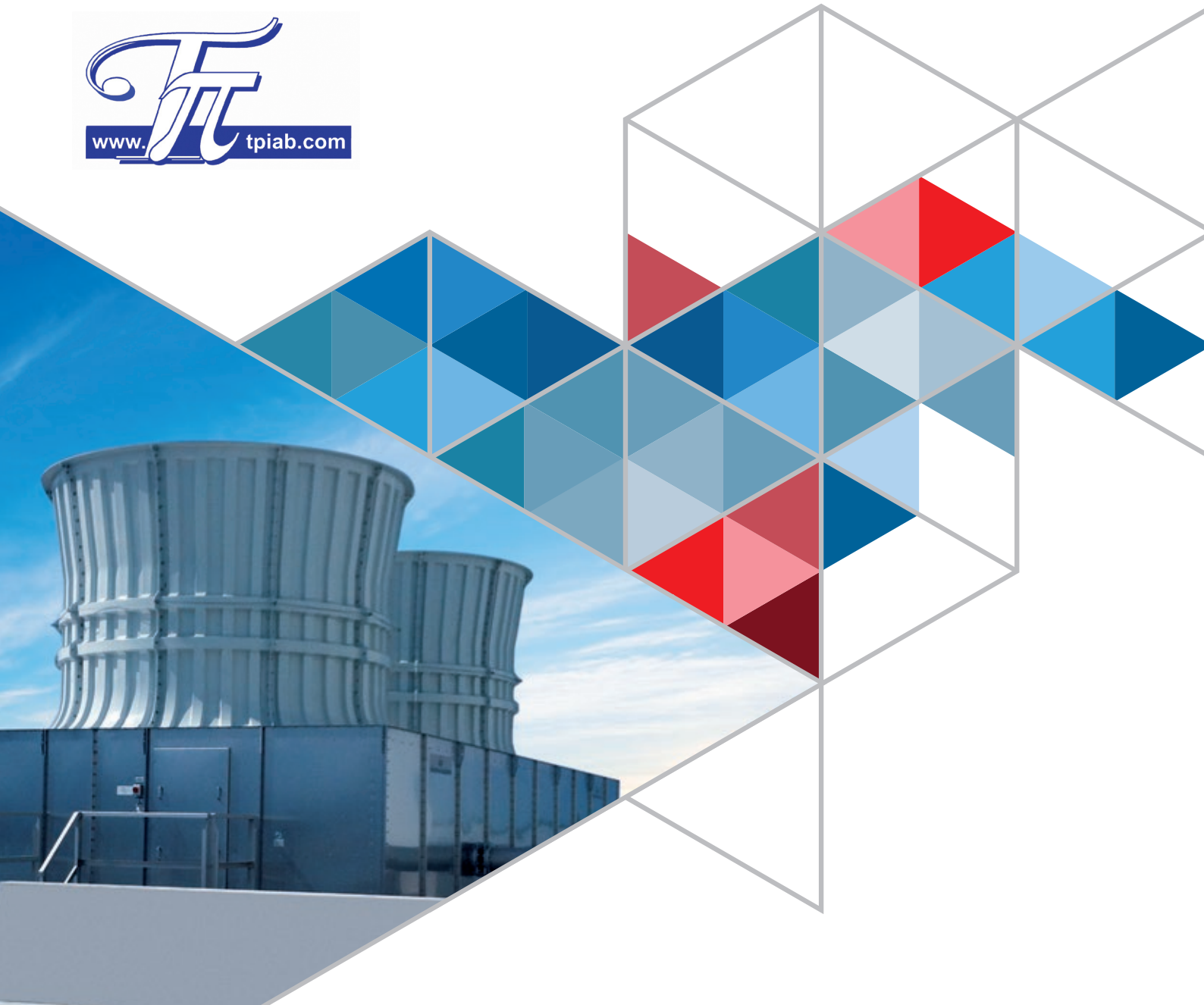



# GOHL-KTK GMBH & JACIR

## *QUALITY – EFFICIENCY – HYGIENE*

- ▶ For more than half a century, the brands JACIR, GOHL and KTK have been synonymous with innovative cooling tower technologies.

Under the umbrella of Cofinair Group, they bring together experience and expertise in the development and manufacturing of highquality cooling towers.



## THE LARGEST EUROPEAN PRODUCT RANGE

### COOLING TOWER PROJECTS ARE VERY DIVERS

But our extremely wide product line and decades of experience allow us to find the right solution for each of our customers. In fact, our systems are already used in nearly all fields of building climate control and industrial process cooling.

## COMMITTED TO THE CUSTOMER BENEFIT

### HYGIENE

All of our system-based solutions are designed and constructed to meet the highest statutory directives and requirements. We support you from the first consultative discussion and up to delivery of comprehensive services, so you get complete solutions from one dependable source.

### QUALITY & ENVIRONMENT

Sustainability is one of the pillars of our corporate philosophy. We strive for quality and longevity in both our products and business relationships. Conservative, environmentally-friendly use of resources and energy plays a central role in the development of new technologies.

### EFFICIENCY

Aside from performance, efficiency is one of the top factors in any investment decision. Low operating costs and very lower service expenses are deciding parameters.



## GUARANTEED PERFORMANCE

The quality we deliver is based on many years of experience and verified by specific certifications. We've done the hard work already! Take advantage of our certifications from independent institutes:

### EUROVENT AND CTI CERTIFICATION

JACIR and GOHL-KTK participate in cooling towers performance ECC Program. Thermal performance has been verified by thermodynamic calculations and independent tests on test stands performed by Eurovent-certified test Quality Management System



Label of DTC ecoTec

**CTI** ▶ member + certification  
**EUROVENT** ▶ association + certification

### CERTIFIED PRODUCT LINES ARE:

DTC ecoTec, KS, KSF, S, VAP

**CHECK ONGOING VALIDITY OF CERTIFICATES: [WWW.EUROVENT-CERTIFICATION.COM](http://WWW.EUROVENT-CERTIFICATION.COM)  
OR [WWW.CTI.COM](http://WWW.CTI.COM)**



### HYGIENIC DESIGN AND MATERIALS

The materials and construction of the cooling towers DT, HK, VK and TOPAZ are based on the specifications of the VDI 2047 Part 2 regulations. We have had our cooling towers tested and confirmed for hygienic construction and materials by a performance test carried out by the „Hygiene-Institut Ruhrgebiet“.



### CORROSION

The independent Institut für Korrosionsschutz Dresden GmbH has verified that the whirl sintering coating process meets the requirements of DIN EN ISO 12944 at the highest corrosion category C5-M.



### ISO 9001

Quality Management System

# CONTENTS

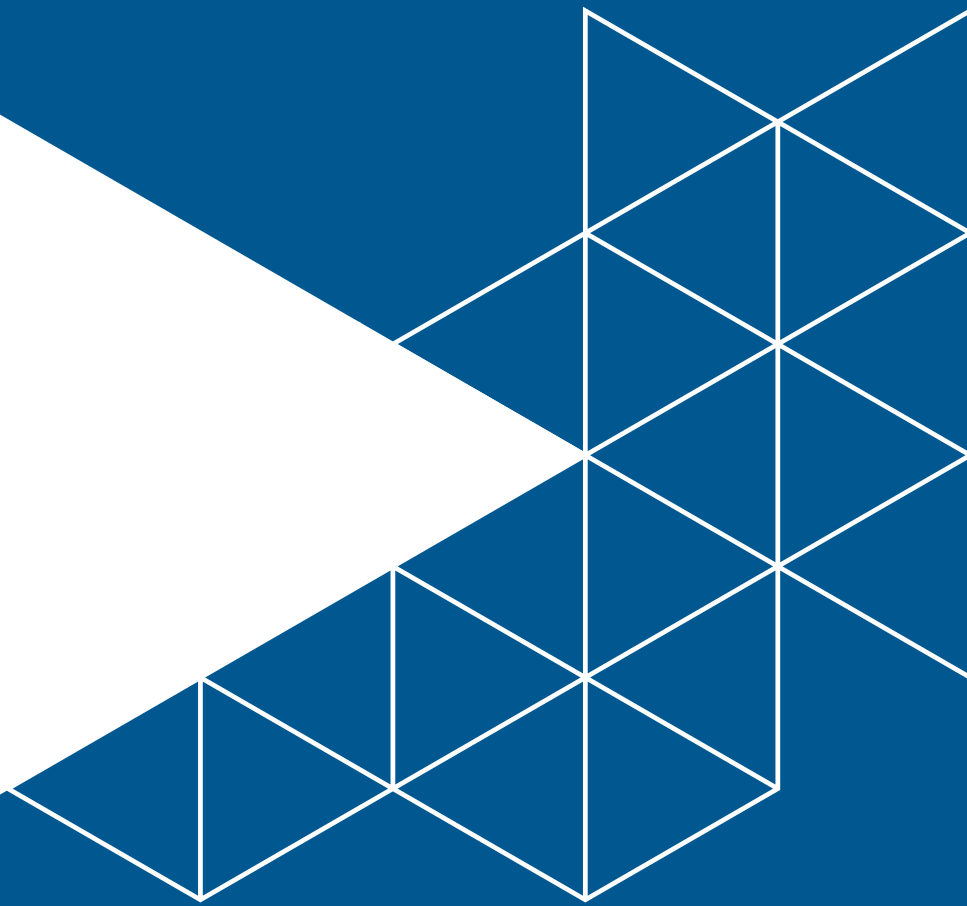

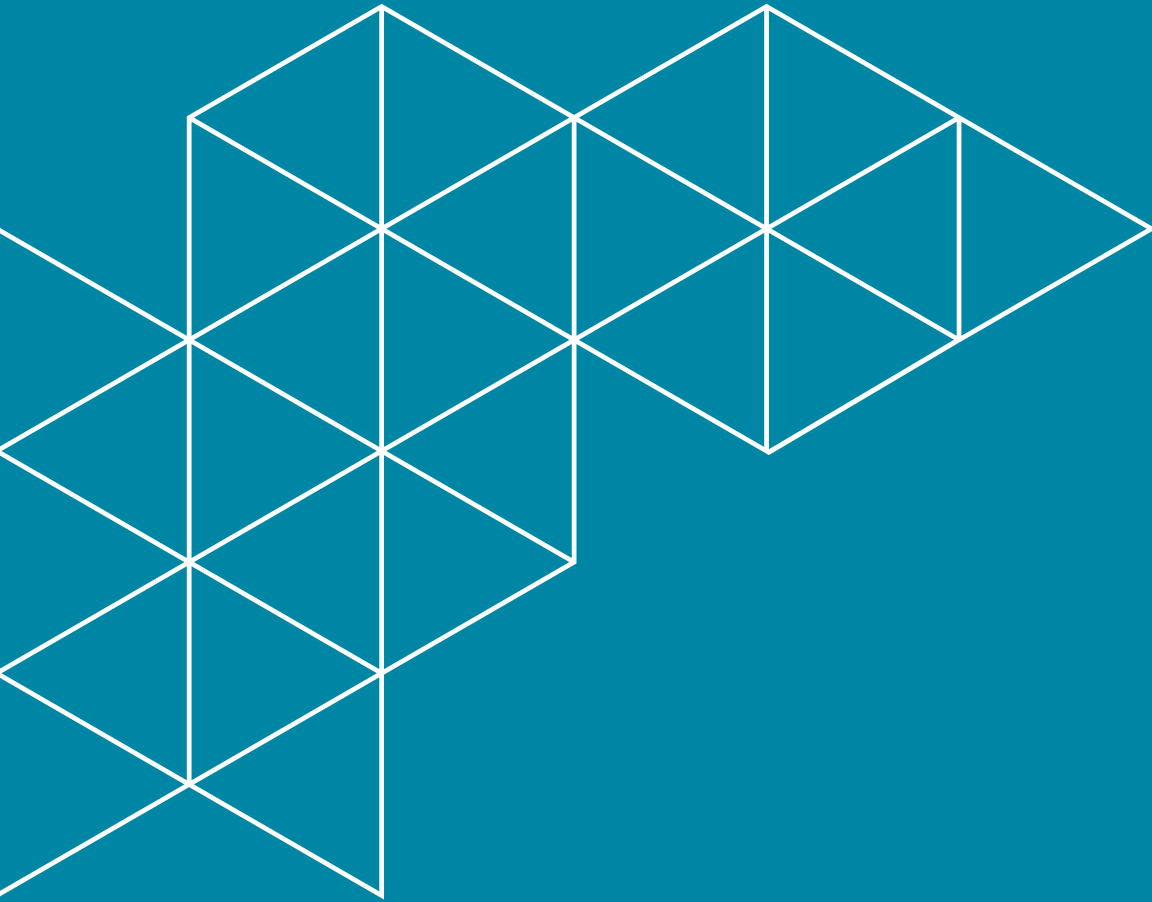

GOHL-KTK GMBH & JACIR	PAGE 2
QUALITY & CERTIFICATIONS	PAGE 4
MATERIALS & SERVICE	PAGE 8
PRODUCTRANGE	PAGE 10
▶ <i>Open-Circuit Cooling Towers</i>	<i>Page 10</i>
▶ <i>Heavy Duty</i>	<i>Page 16</i>
▶ <i>Closed-Circuit Cooling Towers</i>	<i>Page 21</i>
▶ <i>Hybrid Coolers</i>	<i>Page 25</i>
▶ <i>Adiabatic Coolers</i>	<i>Page 30</i>
REFERENCES	PAGE 34



## MATERIALS & SERVICE

- ▶ Cooling towers are frequently subject to extreme weather conditions and must therefore be constructed of corrosion- and weather-resistant materials. Whether you choose stainless steel or whirl-sintering, you can be confident in the durability of our towers.



## CASING AND INFILLS

### CASING options

- whirl-sintering
- 
- X-Steel
- 
- FRP
- 
- sliding PVC
- 
- galvanized steel

### INFILL options

- X-stream
- 400 ppm total suspended solids
- 
- freefilm
- 120 ppm
- 
- PP / pvc
- 12 and 19 mm
- 80 and 100 ppm

## AFTER SALES SERVICE

- ▶ original spare parts
- ▶ hygiene expertise
- ▶ revamping
- ▶ performance increase
- ▶ upgrade
- ▶ taylor made solutions
- ▶ maintenance
- ▶ performance audit
- ▶ rental



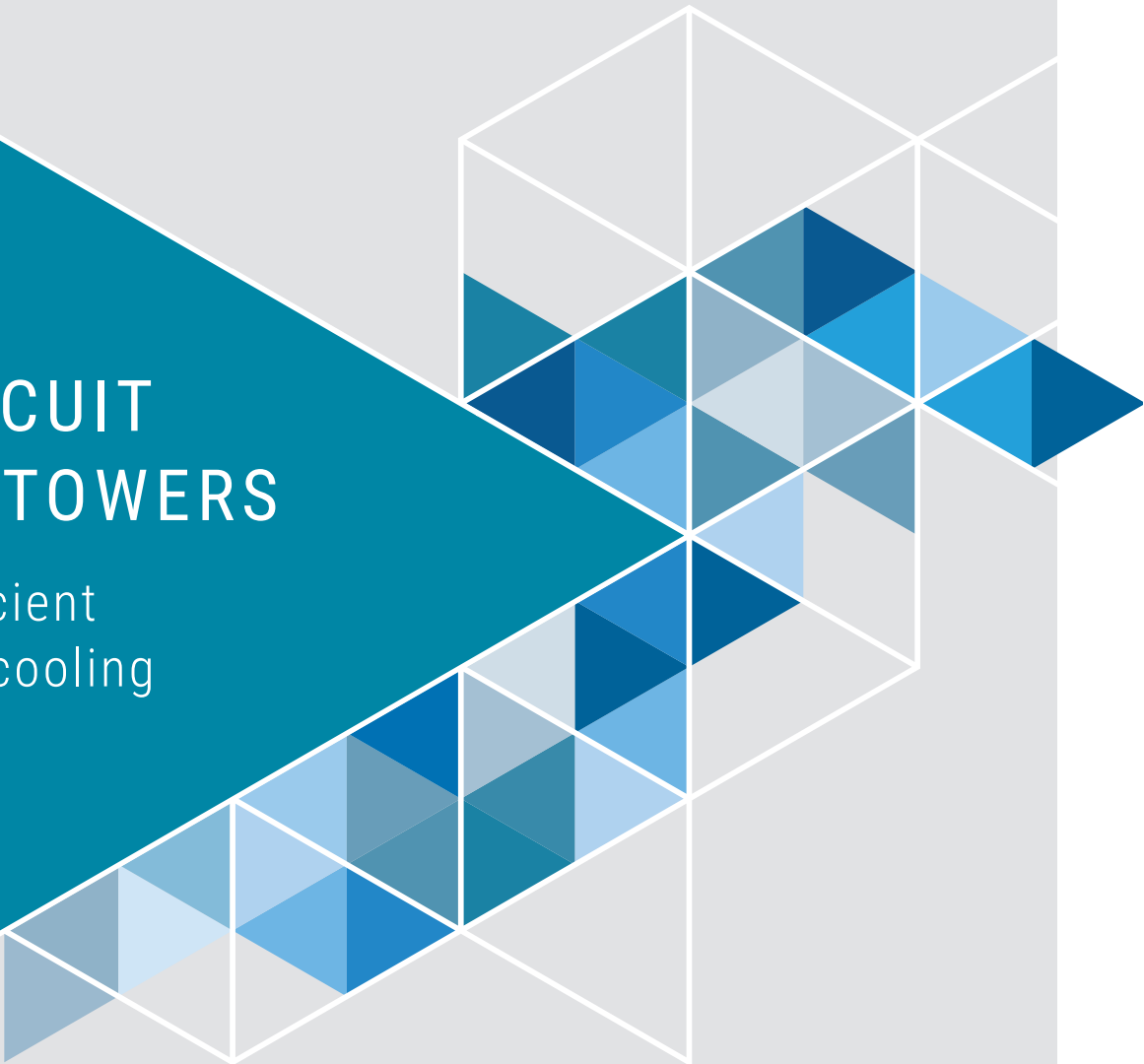

# OPEN-CIRCUIT COOLING TOWERS

The most efficient  
method of re-cooling

## *OPEN COOLING TOWERS HAVE THE HIGHEST POWER DENSITY*

- ▶ They are used wherever cooling machines require large volumes of water and/or when cooling water must be at a low temperature. Open-circuit towers do not have special requirements for water quality.



## FORCED-DRAFT COOLING TOWERS WITH CENTRIFUGAL FANS FOR OPEN-CIRCUIT

- ▶ Pressure-ventilated evaporative cooling towers with radial fans are highly flexible and have a relatively small footprint. Forward curving vanes on the fan impeller allow the fan to work at low speed. The significant pressure reserves allow attachment of additional sound absorbers on the unit.

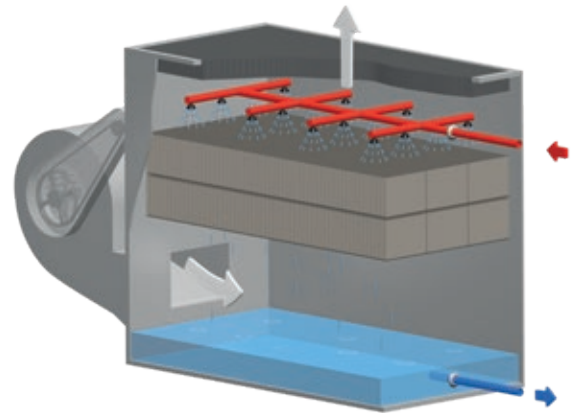

### Series of centrifugal cooling towers **KRD / DT / DT XL / SK / S / ATM / KS**

Forced-draft evaporative cooling towers for open-circuits, with side-mounted centrifugal fans, for indoor and outdoor installation.

#### BENEFITS

- ▶ **Low noise values**
- ▶ **Low weight**
- ▶ **High efficiency**
- ▶ **Low investment**
- ▶ **Extensive accessories available**



#### **DTC ecoTec**

The wet cooling tower series DTC ecoTec is based on the latest calculation methods in the thermodynamic power configuration. Energy consumption and cooling capacity of DTC ecoTec cooling towers are confirmed by **EURO-VENT and CTI**.

## Series of EC-Fans cooling tower **DTC ecoTec**

Forced-draft evaporative cooling towers for open-circuits with maintenance-free EC fans, for indoor and outdoor installation.

### BENEFITS

- ▶ **30% energy savings**
- ▶ **Very low noise**
- ▶ **Sustainably low operating costs**
- ▶ **Maintenance-free EC fans**
- ▶ **Large access opening for service and maintenance**
- ▶ **The best hygienic conditions**

- ▶ The innovative, service-optimized design of DTC ecoTec merges the benefits of indispensable wet cooling towers with economical operation and elevated requirements for hygiene.

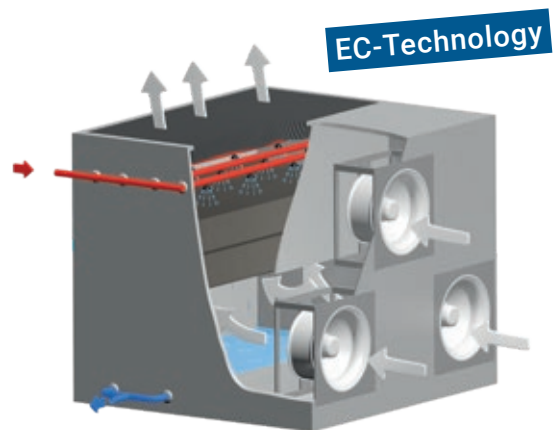

### EASY MAINTENANCE

- ▶ „Walk-Inn” System
- ▶ Maintenance free EC-Ventilators
- ▶ Reduction of components

## FORCED-DRAFT COOLING TOWERS WITH AXIAL FANS FOR OPEN- CIRCUIT

### Series of axial forced-draft KH

Forced-draft evaporative cooling towers for open-circuits, with axial fans, for outdoor installation.

#### BENEFITS

- ▶ Low power consumption
- ▶ Motor fan outside the wet air flow
- ▶ Easy motor and fan access

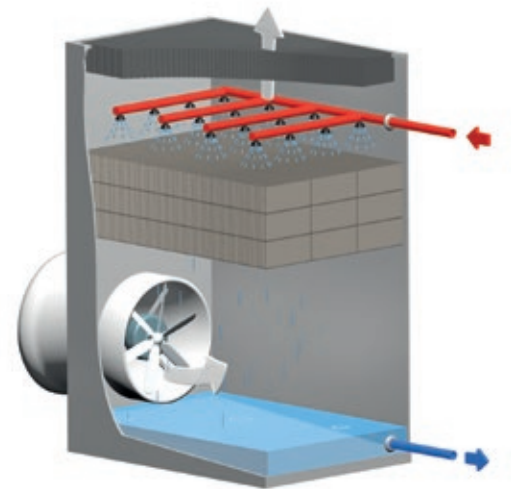

## INDUCED-DRAFT COOLING TOWER WITH AXIAL FANS FOR OPEN- AND CLOSED-CIRCUIT

### Series for axial induced-draft TEC

Induced-draft cooling tower with axial fans for open circuits with Sliding Casing, for outdoor installation.

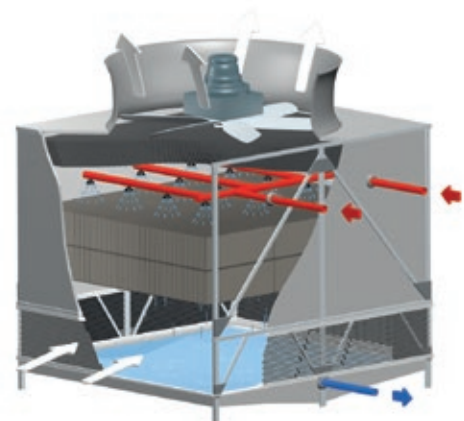

## BENEFITS

- ▶ Corrosion free materials
- ▶ Totally accessible for cleaning
- ▶ No mechanical transmission



## Series for axial induced-draft **KAD / VAP / RMP**

Induced-draft cooling tower with axial fans for open- and closed-circuits,  
– for outdoor installation.

- ▶ Open-circuit axial induced-draft cooling towers have the highest power density. The straightforward design and small footprint, making it suitable for virtually all industrial cooling tasks. High-performance axial fans are characterized by very low power needs. This keeps power consumption and operating costs low. Low-noise fans and additional impact dampers are available for applications with more stringent noise requirements.

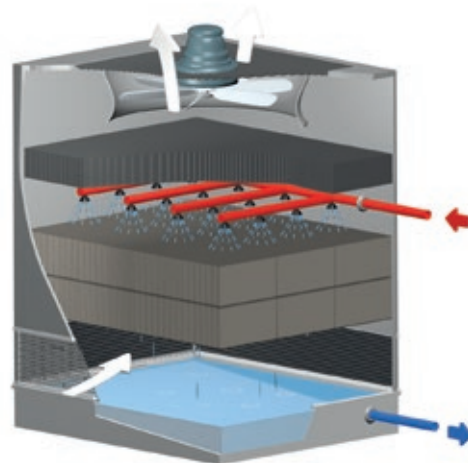

## BENEFITS

- ▶ High-performance with a small footprint
- ▶ Extraordinary flexibility and high power density
- ▶ Equipped with high performance axial fans



- ▶ **KAD IS FOR OPEN AND CLOSED CIRCUITS**



# HEAVY DUTY

Extrem conditions

- ▶ Cooling towers designed for extreme conditions of air and water. Highly polluted air and water with a high concentration of suspended particles are no longer a problem.





## X-STREAM: COMPONENTS FOR EXTREME CONDITIONS OF AIR AND WATER

### BENEFITS

- ▶ **Very high resistance to clogging**
- ▶ **Very high mechanical resistance: 30 Kg/m<sup>2</sup>**
- ▶ **Highly simplified access for cleaning and maintenance**
- ▶ **For water up to 400 ppm suspended solids**

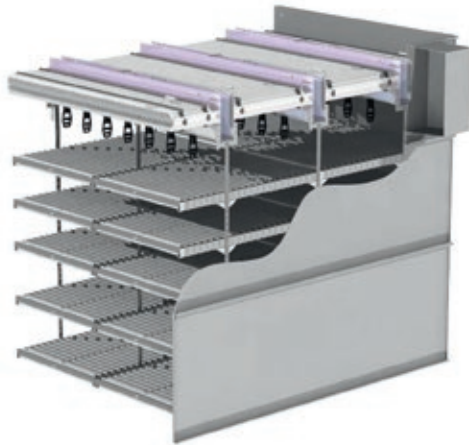

### INFILLS

Made of polypropylene vanes, they distribute the water along the fins, which then falls as drops onto the next lowest fin. The water cools and as it falls from one fin to another, so these drop formation bodies are extremely insensitive to clogging. They can be used for water with a solids content of up to 400 ppm. When using water with a high salt content, thermal expansion makes the X-STREAM drop formation bodies self-cleaning.

### WATER DISTRIBUTION

Water is distributed using X-steel troughs that are equipped with polypropylene nozzles for optimal distribution across the entire air cross-section. These nozzles are designed with a large diameter to avoid clogging even with large amounts of suspended materials. Pressure losses are low (0 to 0.3 m WC) for low pump capacities and large drop formation keeps the water from escaping the tower. The distribution channels are designed to permit high performance even as the volume of water fluctuates greatly. The nozzles can be operated over a range of water volumes.



## X-Stream Series for induced-draft with axial fans **RH / RBH**

from 350 to 660 m<sup>3</sup>/cell

- ▶ high capacity & efficiency



## X-Stream Series for induced-draft with centrifugal fans **RC**

from 10 to 435 m<sup>3</sup>/cell

- ▶ low noise

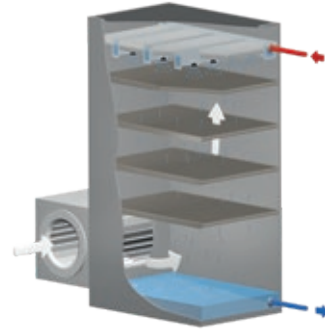

## EASY MAINTENANCE

### CLEANING WITHOUT DISASSEMBLY

- ▶ internal ladders with walkways (optional)
- ▶ multiple and large access doors
- ▶ X-Tract (optional)

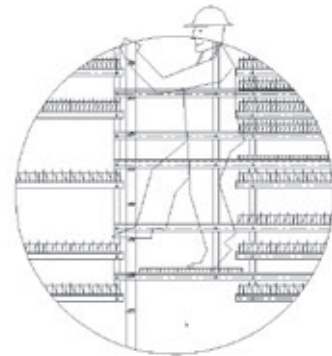

### X-TRACT

Simplified installation and maintenance

X-Tract System has been specially designed to simplify installation and maintenance operations. In a single lift, exchange surface, water distribution and drift eliminators are integrally removed allowing then a complete cleaning of the internals and of the casing on the ground.







# COOLING TOWERS WITH CLOSED-CIRCUIT

Safe

## *NO CONTAMINATION IN THE COOLING WATER NETWORK*

- ▶ Closed cooling towers are preferred particularly in situations with high requirements for cooling water quality, such as machines with narrow cooling channels.

## FORCED-DRAFT EVAPORATIVE COOLING TOWERS WITH CENTRIFUGAL FANS FOR CLOSED-CIRCUIT

- ▶ On the evaporative cooler closed-circuit, water is used to cool a consumer flows through a closed system of coiled tubes that forms the primary circuit. The circulated water is always clean and will not form deposits. The primary circuit is re-cooled through evaporation by wetting the system of coiled tubes with recirculated water from the secondary circuit. These units are used in situations where consumers of cooling water must be operated with clean water.

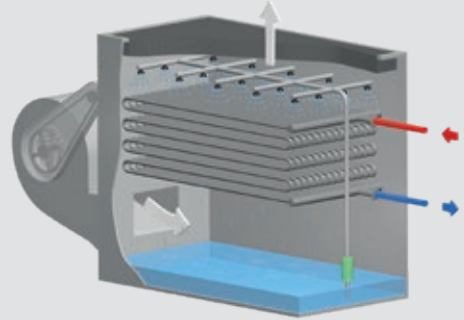

### Series of evaporative cooling towers **KRI / VK**

Forced-draft evaporative cooling towers for closed-circuits, with side-mounted centrifugal fans, for indoor and outdoor installation.

#### BENEFITS

- ▶ **Compact, powerful, and highly adaptable**
- ▶ **No deposits in the cooling water network**
- ▶ **Sound absorption with Inlet and outlet air sound absorbers**



## Centrifugal Evaporative Cooler with heat exchanger SF / CRF / KSF

Forced-draft evaporative cooling towers for closed-circuits, with side-mounted centrifugal fans, for indoor and outdoor installation.

### BENEFITS

- ▶ No freezing without glycol
- ▶ Low noise

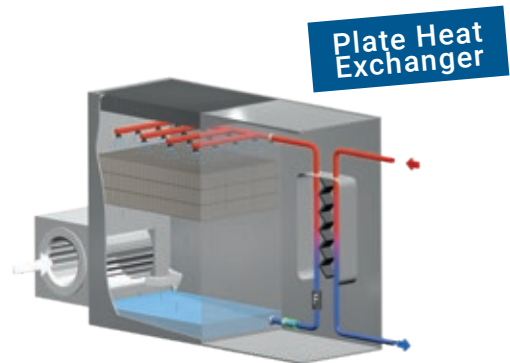

## Axial Evaporative Cooler with heat exchanger KHF / VAPF

Forced-draft evaporative cooling towers for closed-circuits, with axial fans, for outdoor installation.

### BENEFITS

- ▶ No freezing without glycol
- ▶ Full cleaning on primary & secondary circuits

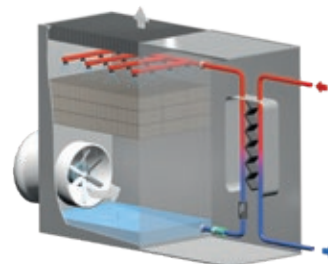
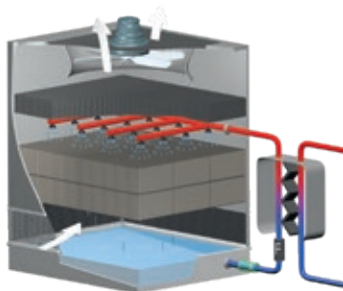

## FRC centrifugal filter

In addition to the natural fouling resistance of the exchanger (high water velocity), this equipment is designed to retain and then remove suspended solids in the water that may offer nourishment for bacteriological growth. Automatic cleaning is OK during the blow-down by induction cycle or by timer, 100% filtering of the water flow at 60 µm efficiency.







# HYBRID COOLERS

Low water consumption

- ▶ Hybrid cooling combines the benefits of both evaporative and dry cooling for environmentally-friendly dissipation of heat into the ambient air.

In some regions, the ambient air temperature varies greatly between summer and winter. Depending on the cooling task, a hybrid cooler may make the most financial sense. In summer, they use the evaporative energy of water. In winter, they dump heat into the ambient air. In winter and during the transition period (the largest portion of operating hours), the unit is operated like a pure dry cooler.

## Series of Hybrid Cooler KAHV

Hybrid coolers for closed circuits with axial fans - stainless steel version - for outdoor installation.

### BENEFITS

- ▶ High switch-over points for dry cooling
- ▶ Low cooling water temperatures
- ▶ No de-sludging necessary
- ▶ Inclined water distribution tubes
- ▶ Low-pressure spray system (3.5 bar)
- ▶ Low energy requirements

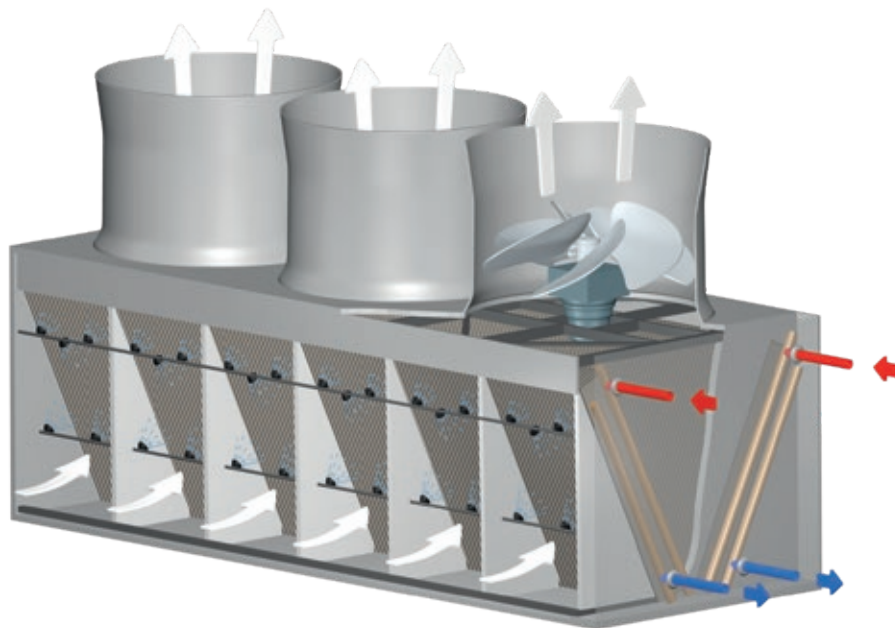

- ▶ Due to their high switch-over point, hybrid coolers can be operated as dry coolers for most of the year. The surface of the heat exchanger must be sprayed only when the ambient air temperatures climb during the summer months. The required evaporative energy cools the fins, and thereby the liquid in the heat exchanger.

An integrated controller automatically optimizes the volume of spray water based on the loads on the unit. The minimal excess water from spraying is not reused.

## EASY MAINTENANCE



## BIOCIDE-FREE

The KAHV and HK hybrid water coolers use high-purity osmosis water that vaporizes almost completely when sprayed. This eliminates the need to treat the water with corrosion protection agents, hardness stabilizers, and biocides. Spraying produces only a minimal amount of excess water. This excess water is not re-used.

Since the spray water is not recirculated, microorganisms have no opportunity to reproduce.

## MICROBE BARRIER

The 0.2  $\mu\text{m}$  hygienic filter captures any microbes that may be present in the spray water. For additional hygienic protection, the spray system is repeatedly flushed with fresh water during times of infrequent spraying.



## Series of Hybrid Cooler **SIM / ATIM / KSIM / KHIM**

Forced-draft Hybrid Coolers for open-circuits with centrifugal fans.

### BENEFITS

- ▶ High efficiency
- ▶ Low cooling water temperature

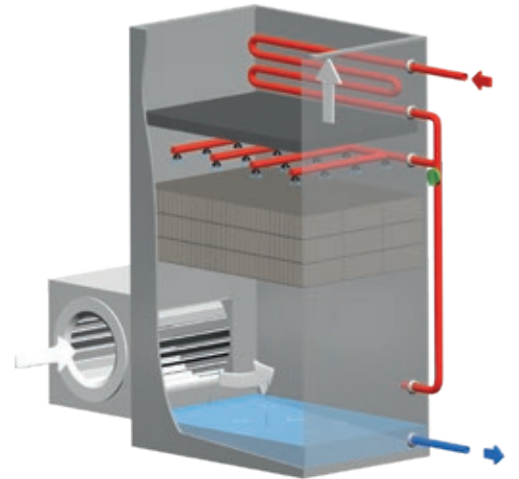

## Series of Hybrid Cooler **SFIM / CRIM / KSFIM / KHFIM**

Forced-draft Hybrid Coolers for closed-circuits with axial fans.

### BENEFITS

- ▶ Glycol free
- ▶ Safe

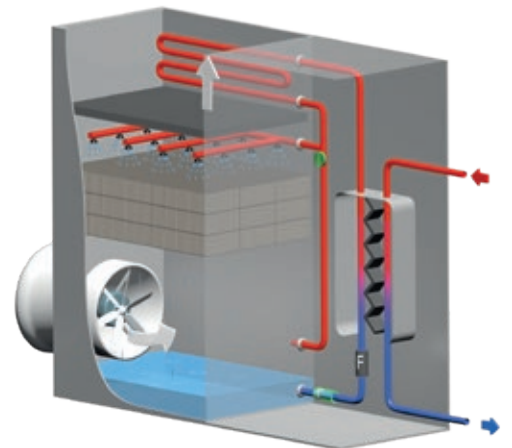

## Series of Hybrid Cooler HK

Forced-draft Hybrid Coolers for closed-circuits with centrifugal fans - whirl-sintered version - for indoor and outdoor installation.

### BENEFITS

- ▶ Low operating costs
- ▶ Low cooling water temperatures
- ▶ Low maintenance expenses

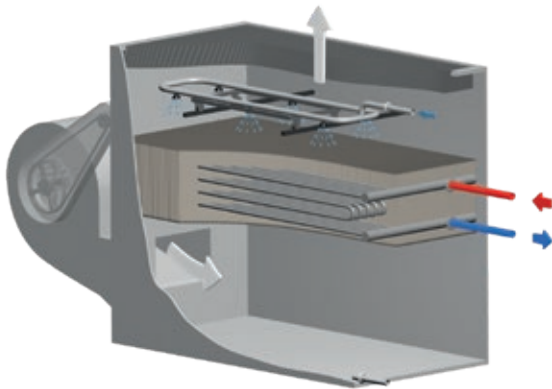

The Hybrid Cooler HK is based on a patented procedure. The regulation dependent on the cooling load makes possible an additional saving of water compared with pure water cooling of up to 75%. The formation of plume is ruled out, and high winter reliability as well as ease of maintenance through the low structural height are guaranteed. A washing device for the automatic cleaning of the heat exchangers prevents deposits of dirt and minerals.





# ADIABATIC COOLER

No Aerosols

*ADIABATIC RE-COOLERS ARE UNITS WHERE THE HEAT EXCHANGER REMAINS DRY.*

- ▶ These re-coolers are characterized by spatial separation of adiabatic evaporation of water into the intake air from the downstream dry cooler.

The process of adiabatic evaporation is time-limited and cools the intake air as needed. This reduces the air temperature as needed when the ambient temperature is higher. The downstream dry cooler dissipates the process heat.



## Series of adiabatic coolers TOPAZ

Induced-draft hybrid dry coolers with adiabatic pre-cooling with axial fans - for outdoor installation.

### BENEFITS

- ▶ Very low operating costs
- ▶ No water treatment necessary
- ▶ No spraying of water into the air flow
- ▶ No aerosols - legionella free
- ▶ Very high switch-over point from wet to dry operation at approx. 23°C
- ▶ Full access to interior spaces makes servicing easy

- ▶ The adiabatic cooler TOPAZ a combination of a dry cooler and an adiabatic cooling track before the air inlet. Adiabatic pre-cooling is activated when the water outlet temperature is higher than needed. The cooling medium is cooled to below the ambient air temperature completely abacterial and without water treatment. (wet to dry switch-over point: 23°C)

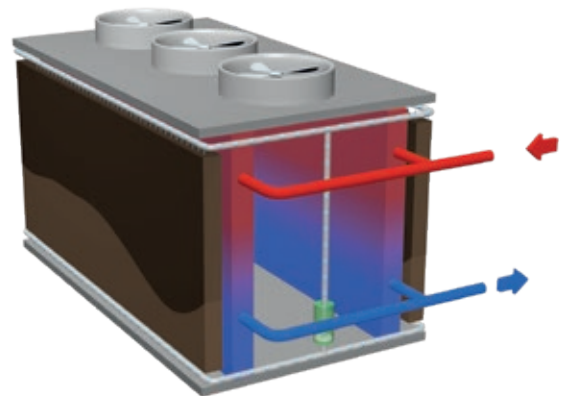

### OPTIONAL:

- ▶ Plug-and-play functionality
- ▶ TOPAZ for winter operation without glycol (drainage function)



## EC-Technology

### MAINTENANCE-FREE AND LOW-NOISE EC AXIAL FANS

The perfect interaction of technically mature components produces the highest possible system efficiency. Optimized flow paths maximize efficiency and minimize noise emissions.



### EASY MAINTENANCE:

- ▶ Access through complete opening
- ▶ Maintenance free EC-Fans



## REFERENCES

### *A CONVINCING PERFORMANCE*

- ▶ As one of the leading experts for recooling, JACIR, GOHL and KTK have made a good name for itself internationally. More than 38,000 cooling tower projects realised worldwide to over 100 countries are clear proof of our capability.



**FINANCE**

Credit Suisse, Bank of America,  
Zürcher Kantonalbank, Commerzbank

**CHEMICALS AND PHARMACEUTICAL  
INDUSTRY**

BASF, Grünenthal, Degussa, Bayer,  
Takeda, GlaxoSmithKline, Hermal

**AUTOMOTIVE INDUSTRY**

Opel, Audi, BMW, VW, Porsche, Airbus  
Mercedes, Ford, Michelin, Toyota

**FOOD INDUSTRY**

Danone, Nestlé

**ENERGY**

EON, RWE, Siemens, Philipps,  
Thyssen Krupp, Lech Stahlwerke,  
Alstom Power, Total, Atlas Elektronik

**MEDIA & STORES**

Springer, Bundesdruckerei, SWR,  
Burda Medien, Bayerischer Rundfunk, WDR,  
IKEA, Louis Vuitton,

**PUBLIC INSTITUTION**

Airport Hamburg, Airport Frankfurt,  
Messe München, Messe Hamburg,  
Messe Düsseldorf, Airport Stuttgart,  
Aéroport de Paris, Reed Exhibitions Wien,  
Airport Hannover



**TPI Klimatimport AB**  
[WWW.TPIAB.COM](http://WWW.TPIAB.COM)

**GOHL-KTK GmbH**  
[WWW.KUEHLTURM.DE](http://WWW.KUEHLTURM.DE)

**JACIR**  
[WWW.JACIR.FR](http://WWW.JACIR.FR)

**TPI Klimatimport AB**  
Runstensvägen 5  
175 61 Järfälla  
Tel.: 08-445 77 90  
[info@tpiab.com](mailto:info@tpiab.com)

**GOHL-KTK GmbH**  
Schlosserstraße 5  
76448 Durmersheim  
Germany  
Tel.: +49 7245 91916 0  
[kuehlturm@kuehlturm.de](mailto:kuehlturm@kuehlturm.de)

**SUBSIDIARY GOHL-KTK GmbH**  
Wilhelm-Moriell-Str. 10  
78315 Radolfzell  
Germany  
Tel.: +49 7732 89032 0  
[service@kuehlturm.de](mailto:service@kuehlturm.de)

**JACIR**  
11, rue Jean Moulin,  
77348 Pontault-Combault Cedex  
France  
Tel.: +33 1 6443 5320  
[contact@jacir.fr](mailto:contact@jacir.fr)