

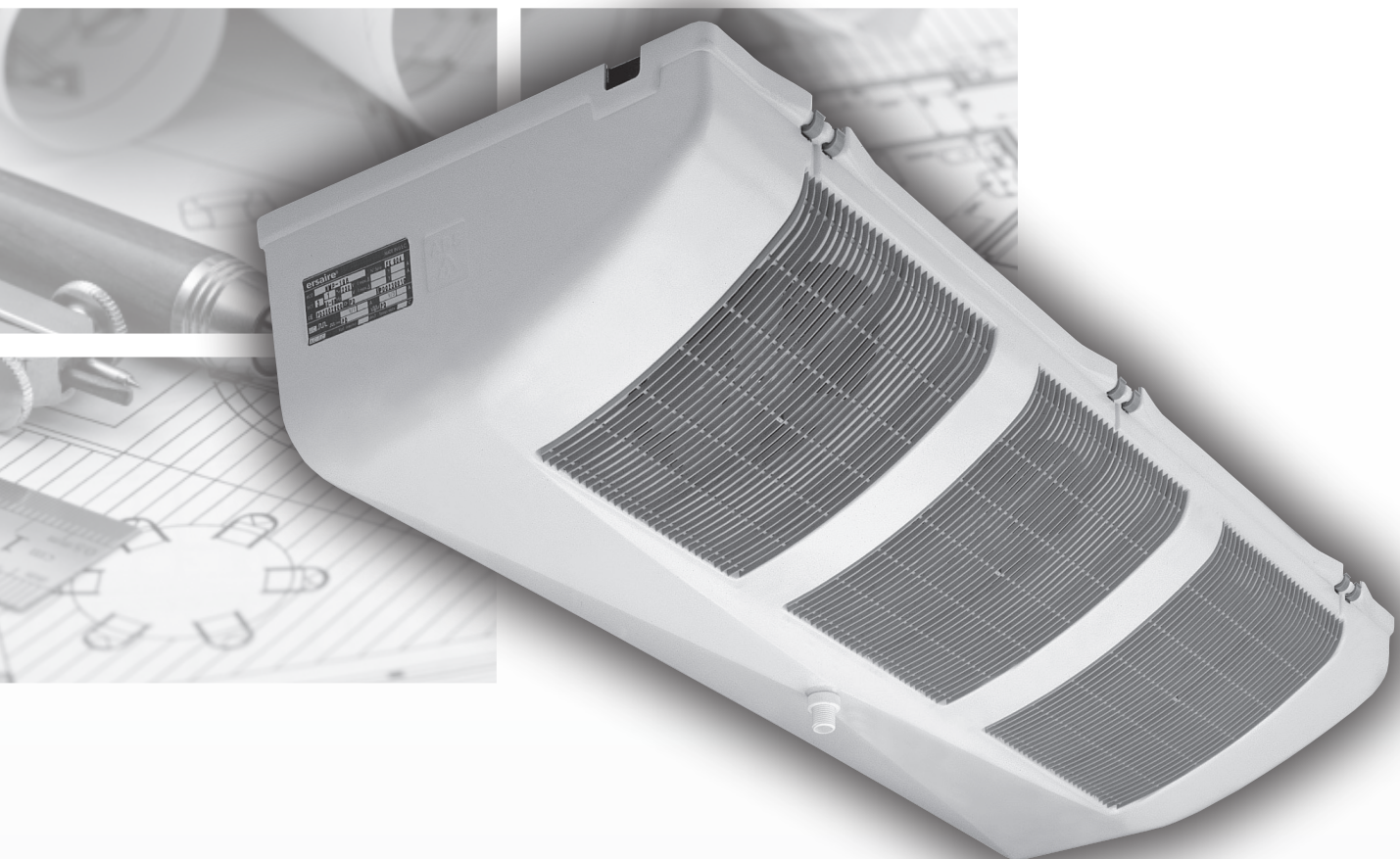

Fläktförångare

MR - MRE



INSTALLATIONSMANUAL

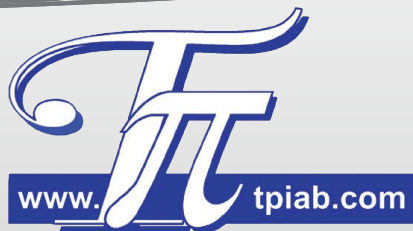

FRIGA-BOHN



1. ÖPPNA HÖLJET OCH ANSLUTNING AV DOPPLÅT

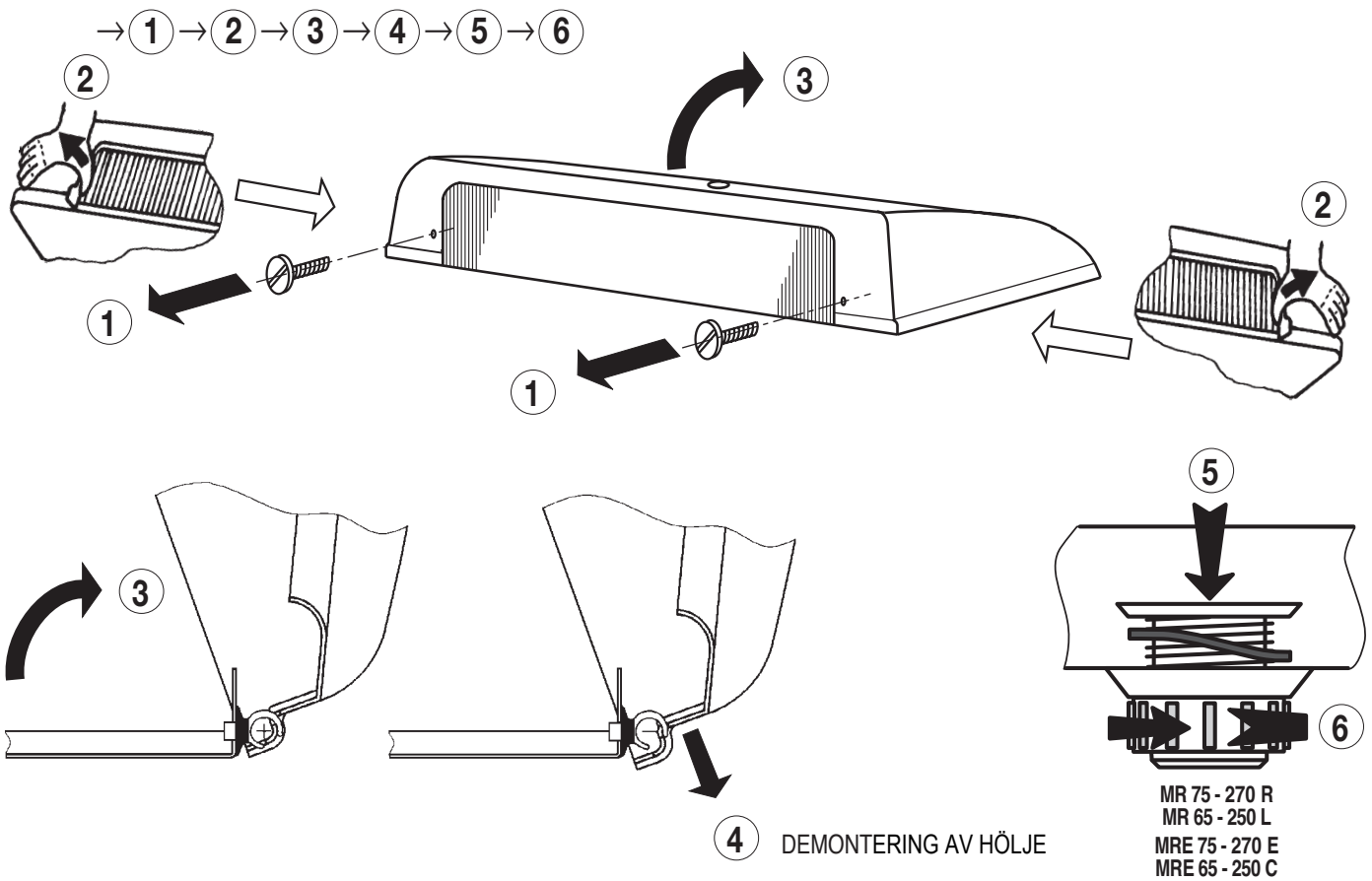

2. KÖLDMEDIEANSLUTNING

→ ① → ② → ③ → ④

MR 75 - 110 - 135 R / MR 65 - 100 - 120 L
MRE 75 - 110 R / MRE 65 - 100 L

→ ② → ③ Montering av expansionsventil

① INGÅNG

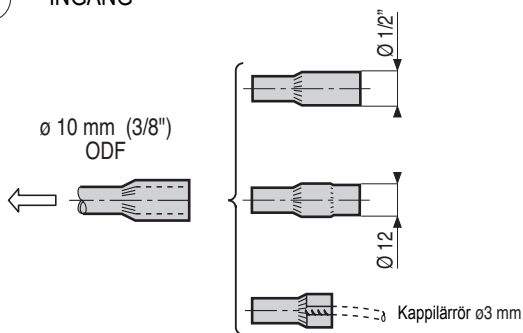

④ UTGÅNG

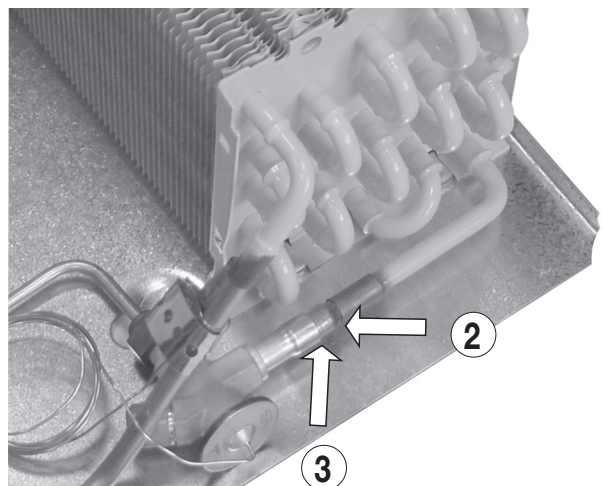

MR 160 - 180 - 210 - 270 R
 MR 140 - 170 - 190 - 250 L
 MRE 135 - 160 - 180 - 210 - 270 E
 MRE 120 - 140 - 170 - 190 - 250 C

→ ② → ③

⎵
 ⓐ

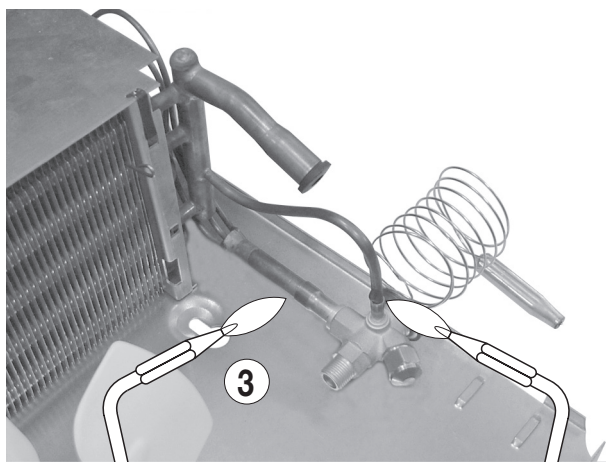

ⓐ } ②

MR 160 - 180 - 210 - 270 R / MR 140 - 170 - 190 - 250 L
 MRE 135 E / MRE 120 C

④ UTGÅNG



① INGÅNG

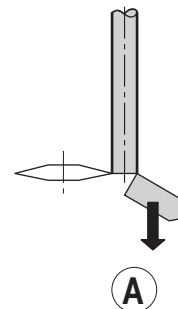
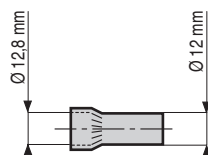

MRE 160 - 180 - 210 E / MRE 140 - 170 - 190 C

④ UTGÅNG



MRE 270 E / MRE 250 C

④ UTGÅNG



3. MONTERING OCH RÖRDRAGNING

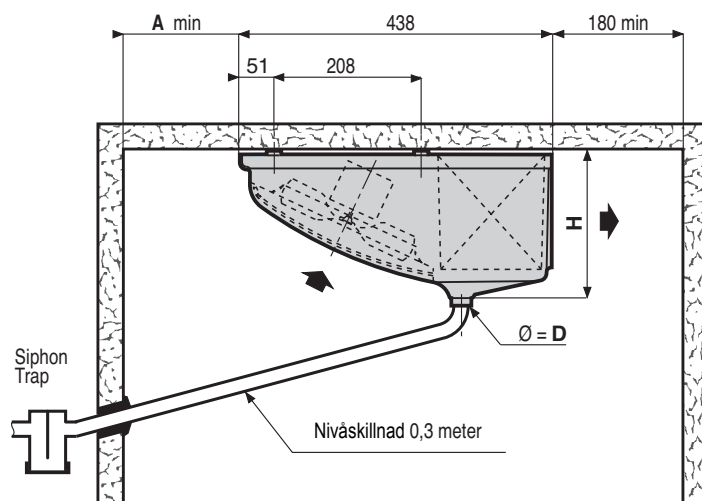
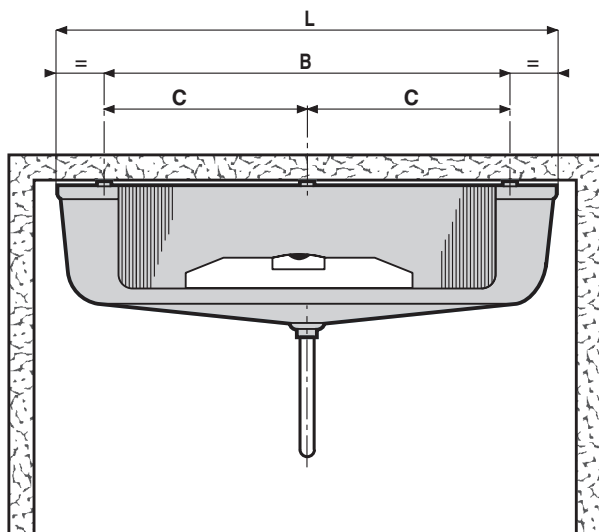

A min : 90 mm Är nödvändigt för att kunna vrida
 160 mm är nödvändigt för demontering

	MR 75 R MR 65 L MRE 75 E MRE 65 C	MR 110 - 135 R MR 100 - 120 L MRE 110 - 135 E MRE 100 - 120 C	MR 160 - 180 - 210 R MR 140 - 170 - 190 L MRE 160 - 180 - 210 E MRE 140 - 170 - 190 C	MR 270 R MR 250 L MRE 270 E MRE 250 C
L	514	784	1174	1504
B	326	596	986	1316
C			493	658
H	209	227	227	209
D	1"G	32	32	1"G



4. MONTERING I TAK

→ ① → ② → ③ → ④ → ⑤

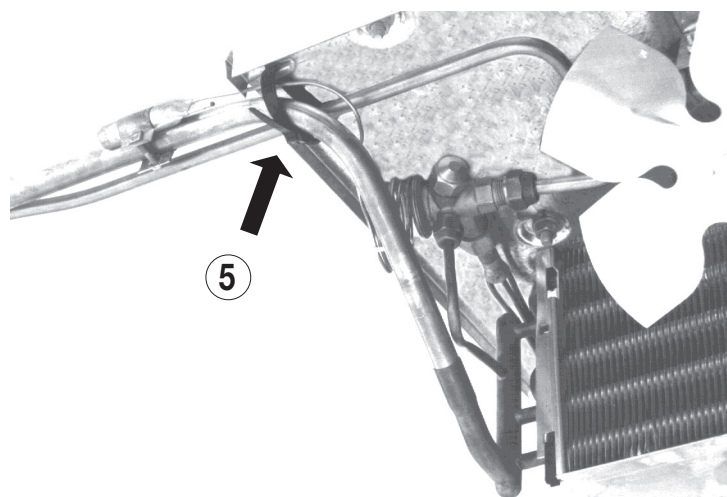
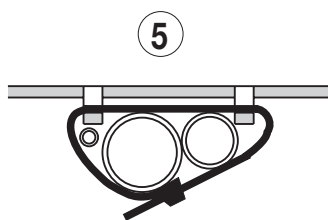
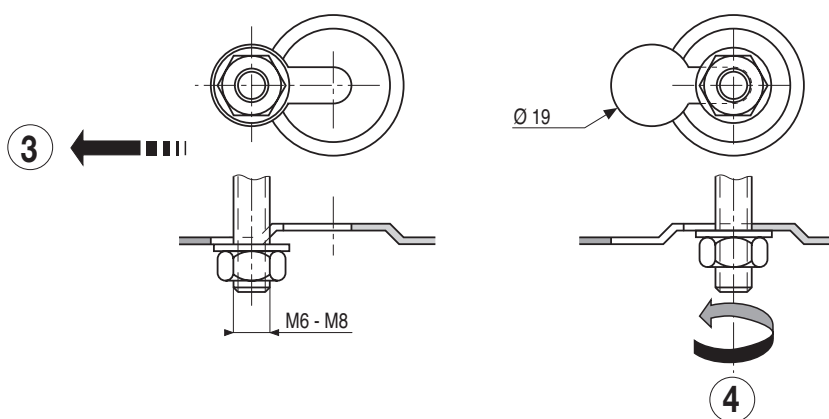
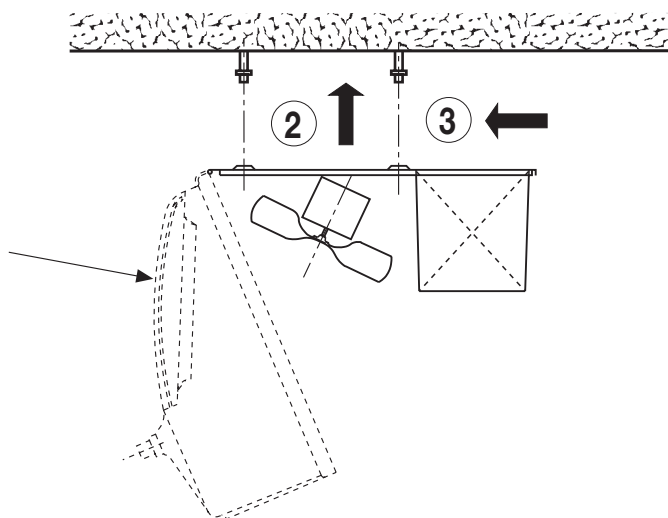
- ① Distans A kortare än 160 mm (se sid 3): montera höljet och dra sedan åt låsmutterarna i taket



5. EL-ANSLUTNING

		MR 75 R 65 L	MRE 75 E 65 C	MR 110 - 135 R 100 - 120 L	MRE 110 E 100 C	MRE 135 E 120 C	MR 160 180 - 210 R MR 140 170 - 190 L	MRE 160 - 180 E 140 - 170 C	MRE 210 E 190 C	MR 270 R 250 L	MRE 270 E 250 C
 50 Hz	W	38	38	76	76	76	114	114	114	152	152
	A	0,24	0,24	0,48	0,48	0,48	0,72	0,72	0,72	0,96	0,96
 RB	W		400		440	730		960	1200		1300
	A		1,8		2	3,3		4,4	5,5		7,3

Tilval: RE dräneringsvärmare 50 W /m

MR 110 - 135 R MR 100 - 120 L

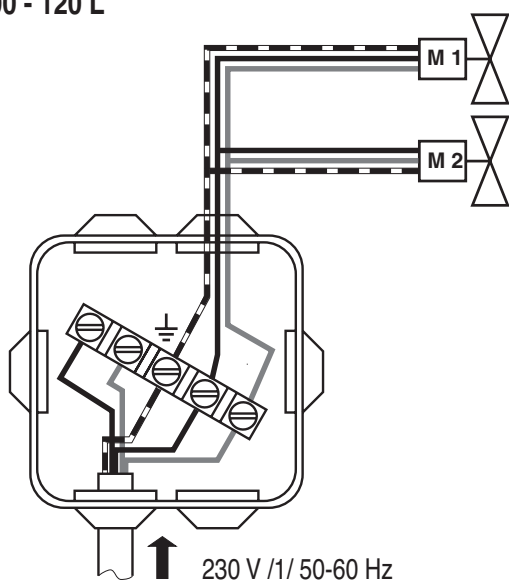

MRE 75 - 110 - 135 R MRE 65 - 100 - 120 L

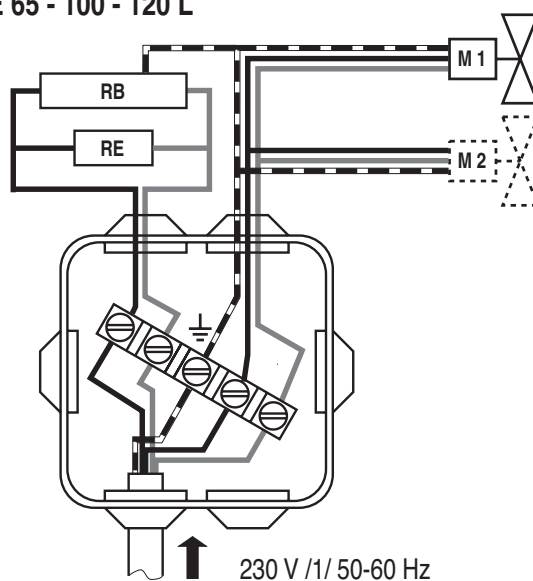

MR 160 - 180 - 210 - 270 R MR 140 - 170 - 190 - 250 L

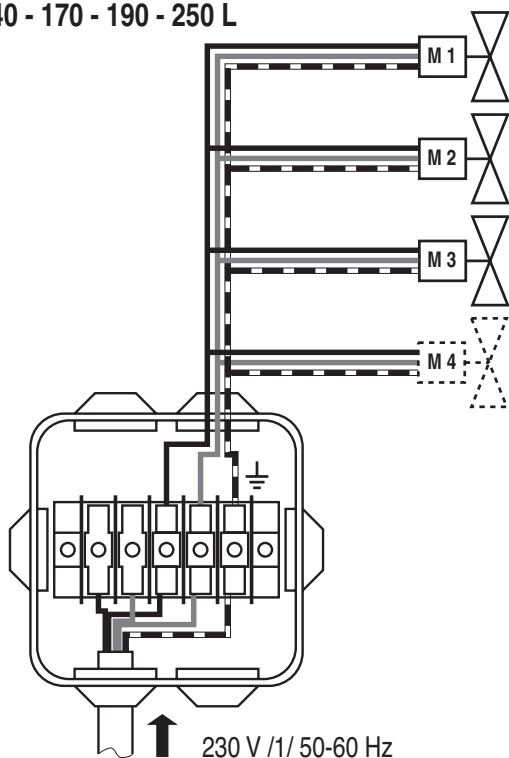

MRE 160 - 180 - 210 - 270 E MRE 140 - 170 - 190 - 250 C

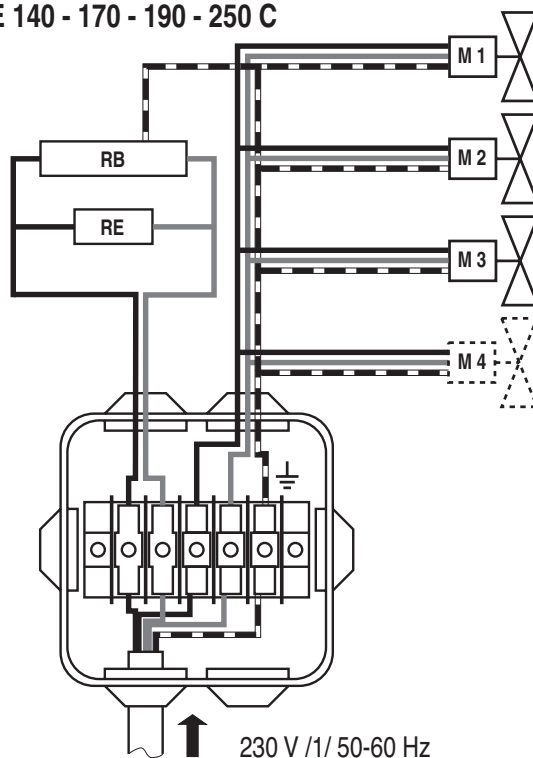

6. PLACERING AV GIVARE (För avfrostnings kontroll via termostat)

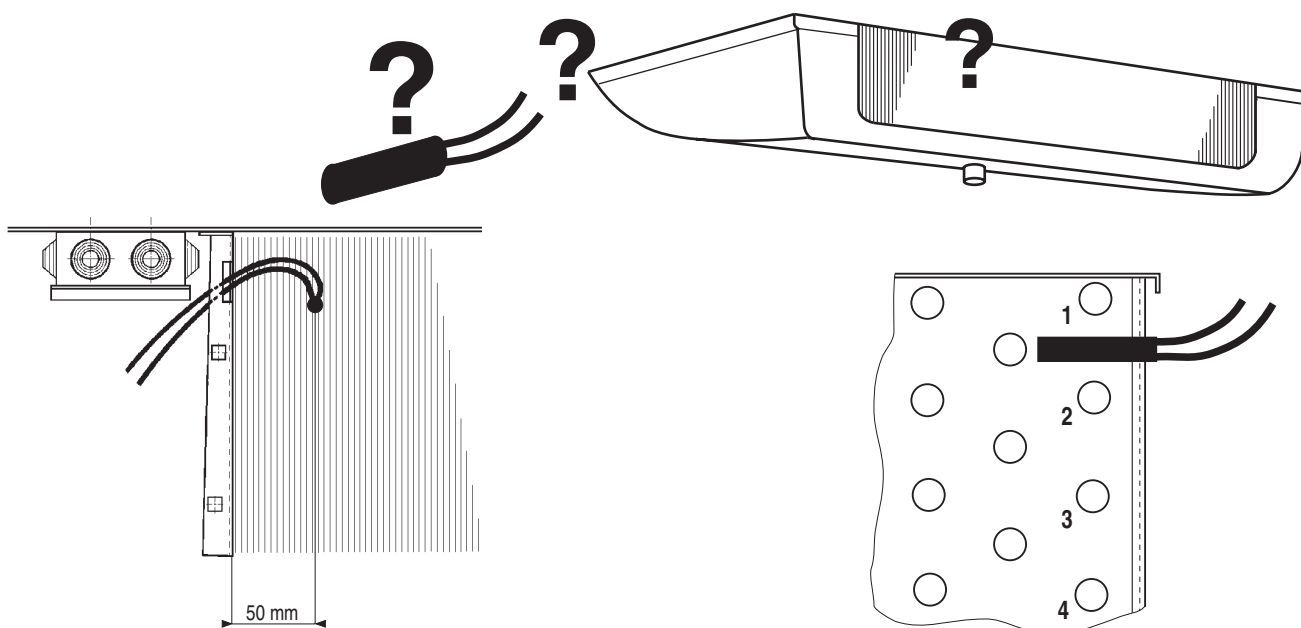

7. UTBYTE AV AVFROSTNINGSVÄRMARE

A. DEMONTERING → ① → ② → ③ → ④

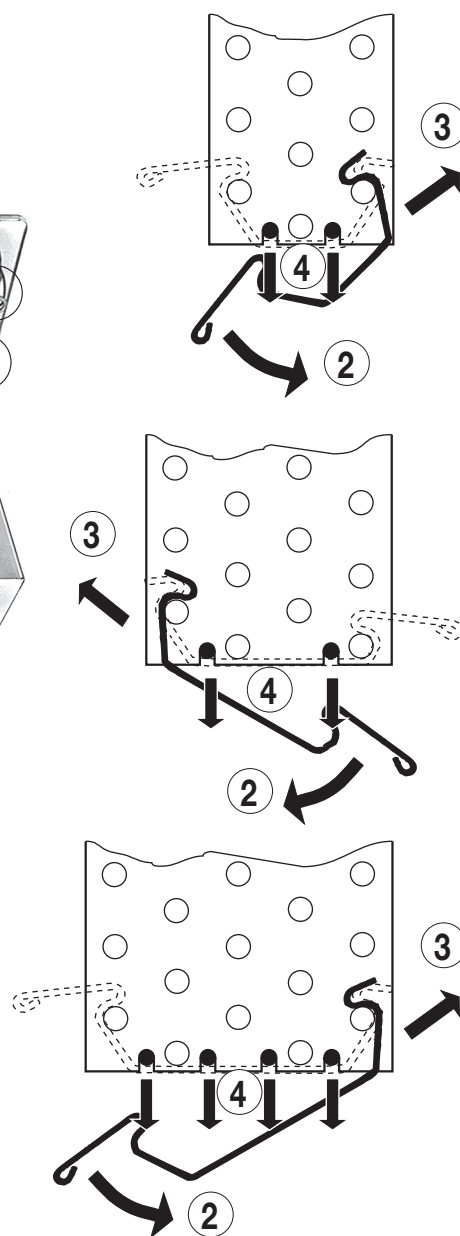
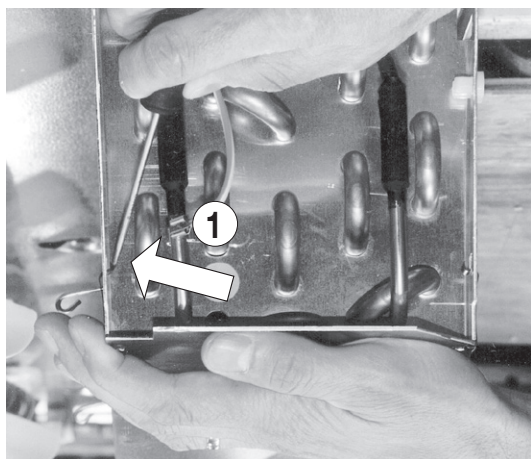
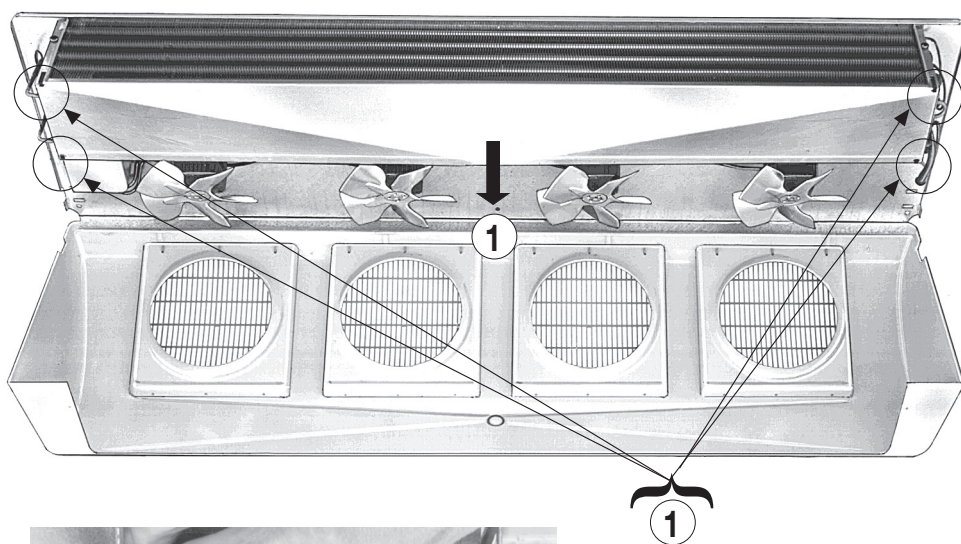

A. MONTERING

→ ① → ② → ③ → ④ → ⑤ → ⑥

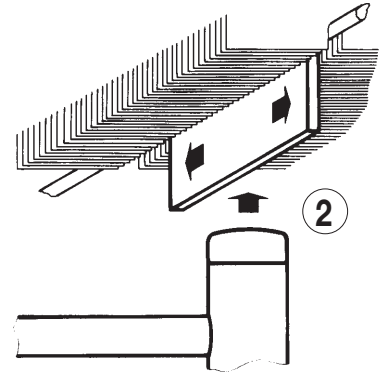
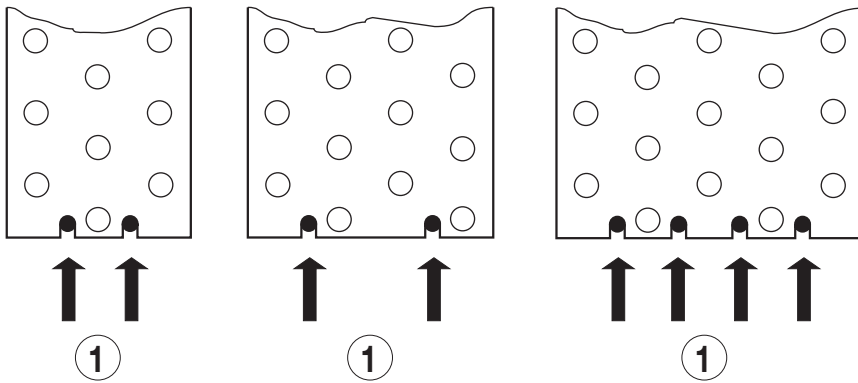

PLACERING AV CLIPS

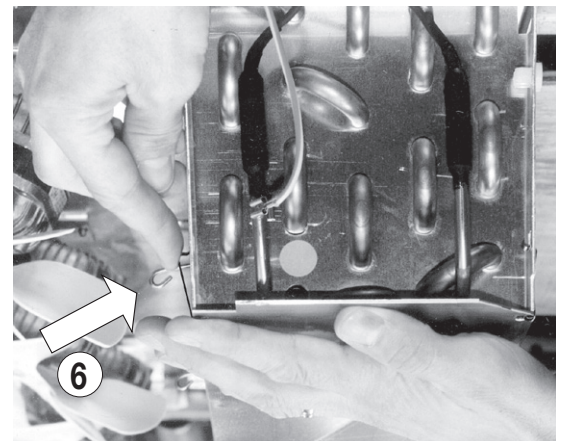
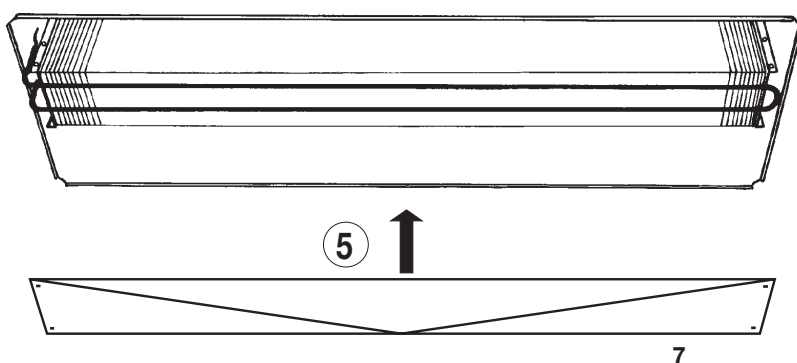
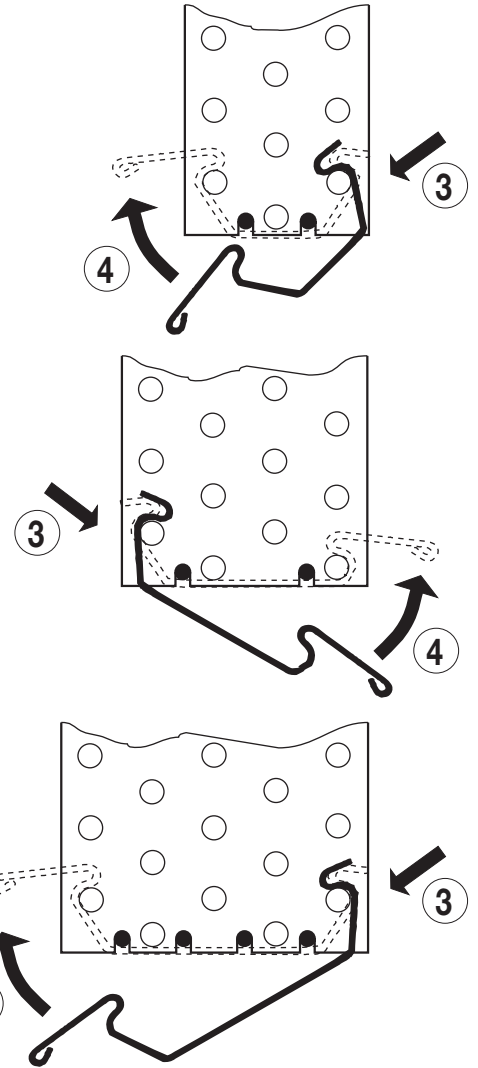
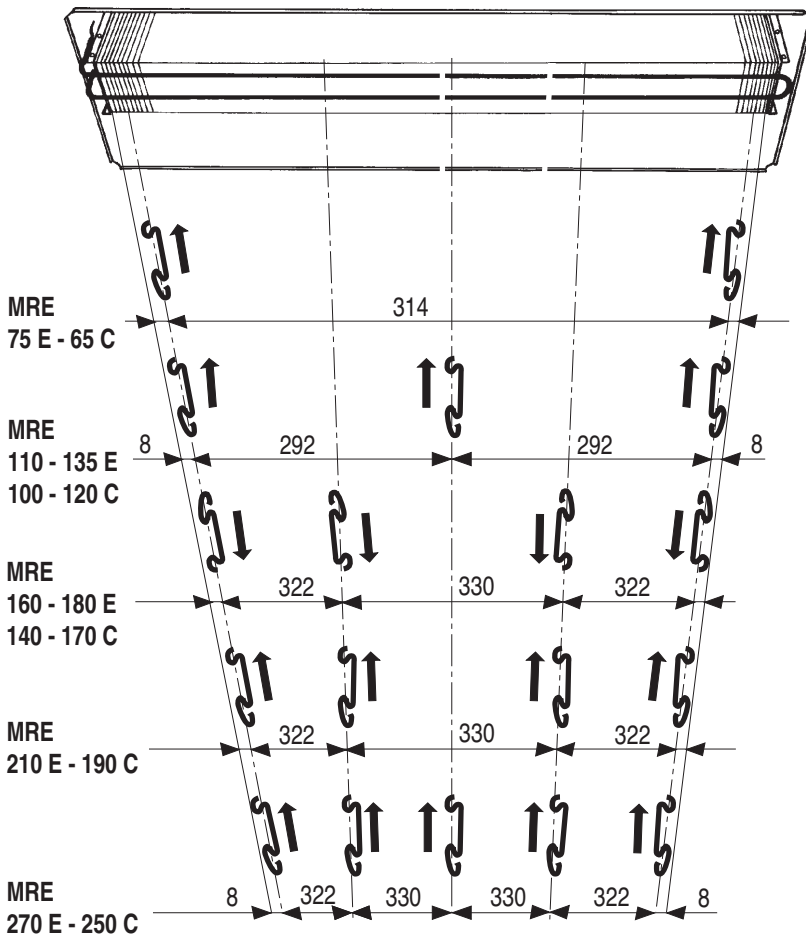

8. UNDERHÅLL

Rengör regelbundet med icke aggressiv lösning och skölj med rent vatten

- batteri : Skydda motorn med plast, Max 3 bar vattentryck och var försiktig med lameller, fläktblad, fläktvakter och hölje.

Kontrollera vid start och med jämna mellanrum, så att skruvarna inte lossat och att elkablarna sitter fast.

FELSÖKNING

Om motorn inte startar: kontrollera att spänning finns fram och att fläktbladen snurrar fritt

Om enheten vibrerar: kontrollera att fläktbladen är fria från is, byt ut eventuell defekt komponent.



TPI Klimatimport AB
info@tpiab.com