

Unit Coolers
GTA

Notice originale
Original notice
Originale Hinweise
Original aviso

N° IN0027500-A
09.2014



**NOTICE TECHNIQUE D'INSTALLATION
INSTALLATION INSTRUCTIONS
INSTALLATIONSNOTIZ
MANUAL TECNICO DE INSTALACION**



FRIGA-BOHN

HK[®] REFRIGERATION

1 - DIMENSIONS - DIMENSIONAL DATA - DIMENSIONES - ABMESSUNGEN

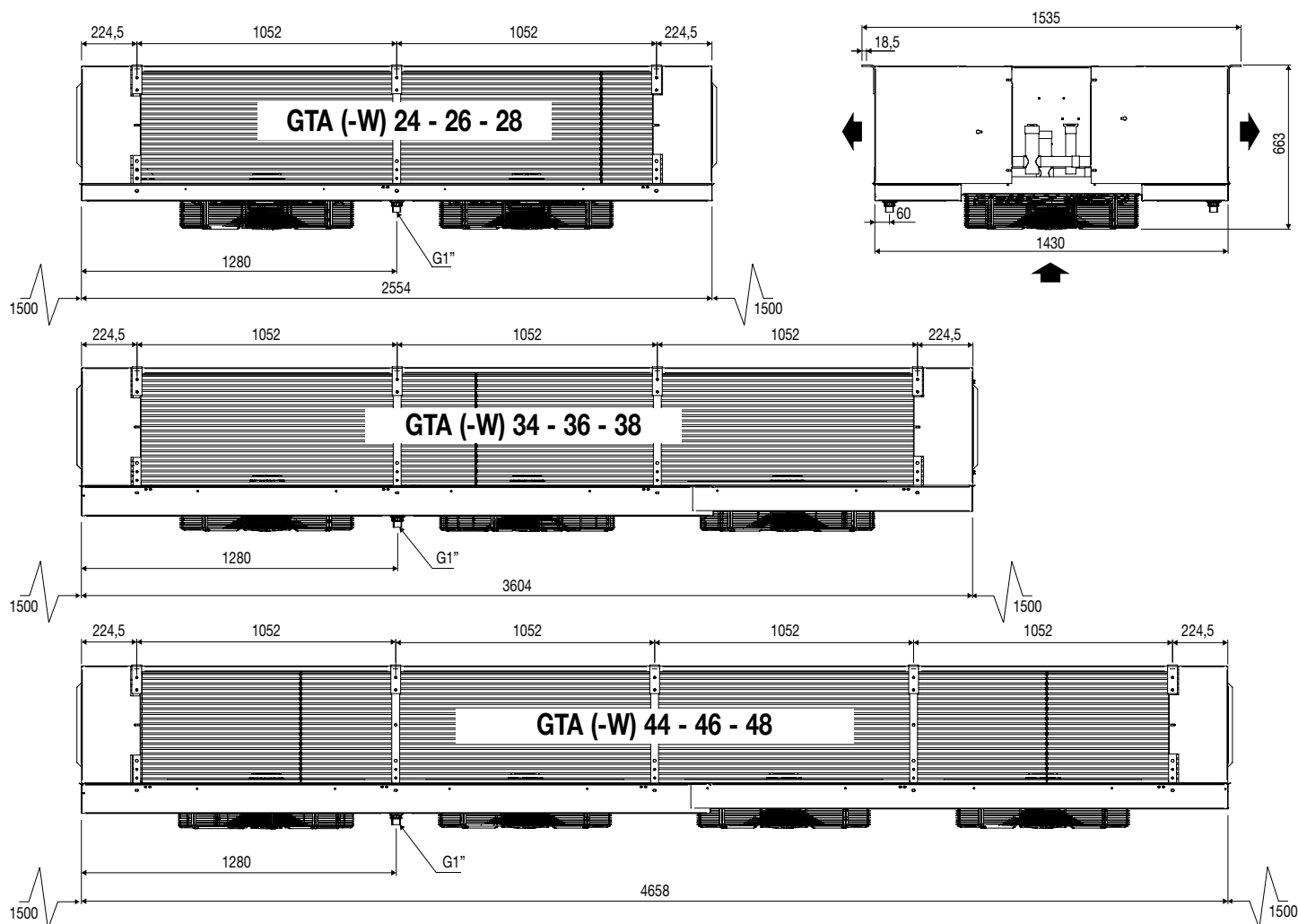

Modèles - Models - Modelos - Modelle	GTA (-W) ...	24	26	28	34	36	38	44	46	48
Ventila. - Fan	Nb max. kit Ø 630 mm	2	2	2	3	3	3	4	4	4
Dégivrage élect. - Elect. defrost	Nb/No/Anz.	Ω	12	12	12	12	12	12	12	12
Desecarse Elect - Eleckt. Abtauung	W Total	9000	9000	9000	13800	13800	13800	18000	18000	18000
E1U (4)	400 V/3/50 Hz	A Total	13	13	13	20	20	20	26	26
Dégivrage élect. - Elect. defrost	Nb/No/Anz.	Ω	12+6	12+6	12+6	12+6	12+6	12+6	12+6	12+6
Desecarse Elect - Eleckt. Abtauung	W Total	13500	13500	13500	20700	20700	20700	27000	27000	27000
ELU+EEK (4)	400 V/3/50 Hz	A Total	19,5	19,5	19,5	30	30	30	39	39
Dégivrage élect. - Elect. defrost	Nb/No/Anz.	Ω	6	6	6	6	6	6	6	6
Desecarse Elect - Eleckt. Abtauung	W Total	4500	4500	4500	6900	6900	6900	9000	9000	9000
ECK kit or EEK kit	400 V/3/50 Hz	A Total	6,5	6,5	6,5	10	10	10	13	13
	Nb/No/Anz. max. kit	ECK	1	1	2	1	1	2	1	2
		EEK	1	1	1	1	1	1	1	1
Poids net - Net weight - Peso neto - Nettogewicht	kg	260	292	316	349	395	433	457	506	549
	GTA (-W) ... R 4D	24	26	28	34	36	38	44	46	48
Entrée - Inlet - Entrada - Eintritt	Ø	1"1/8	1"3/8	1"3/8	1"3/8	1"5/8	1"5/8	1"5/8	2 x 1"3/8	2 x 1"3/8
Sortie - Outlet - Salida - Austritt	Ø	1"5/8	1"5/8	1"5/8	2"1/8	2"1/8	2"1/8	2"1/8	2"5/8	2"5/8
	GTA (-W) ... R 6D/Y	24	26	28	34	36	38	44	46	48
Entrée - Inlet - Entrada - Eintritt	Ø	1"1/8	1"1/8	1"3/8	1"3/8	1"5/8	1"5/8	1"5/8	1"5/8	2 x 1"3/8
Sortie - Outlet - Salida - Austritt	Ø	1"3/8	1"5/8	1"5/8	2"1/8	2"1/8	2"1/8	2"1/8	2"1/8	2"5/8
	GTA (-W) ... L 4D	24	26	28	34	36	38	44	46	48
Entrée - Inlet - Entrada - Eintritt	Ø	1"1/8	1"3/8	1"3/8	1"3/8	1"5/8	1"5/8	1"5/8	2 x 1"3/8	2 x 1"3/8
Sortie - Outlet - Salida - Austritt	Ø	1"5/8	1"5/8	1"5/8	2"1/8	2"1/8	2"1/8	2"1/8	2"5/8	2"5/8
	GTA (-W) ... L 6D/Y	24	26	28	34	36	38	44	46	48
Entrée - Inlet - Entrada - Eintritt	Ø	1"1/8	1"1/8	1"3/8	1"3/8	1"3/8	1"5/8	1"5/8	1"5/8	2 x 1"3/8
Sortie - Outlet - Salida - Austritt	Ø	1"3/8	1"3/8	1"3/8	1"5/8	1"5/8	2"1/8	2"1/8	2"1/8	2"5/8

2 - MONTAGE EVAPORATEUR ET CONDUITES
LOCATION UNIT COOLER AND PIPING
MONTAJE EVAPORADOR Y TUBERIAS
INSTALLATION DES VERDAMPFERS UND DER LEITUNGEN

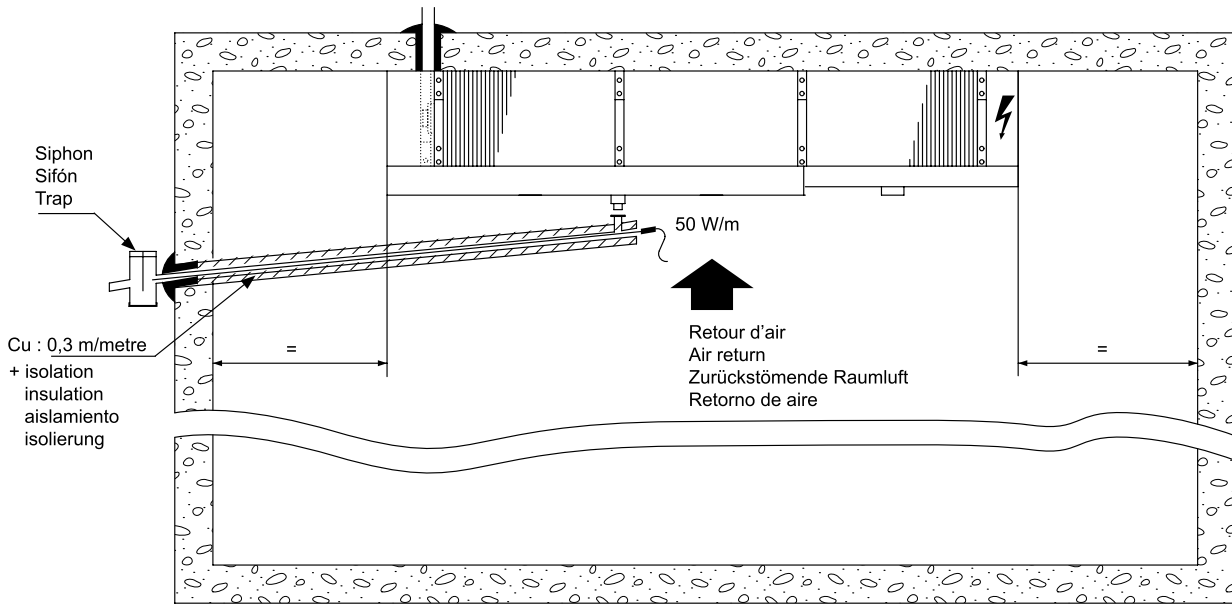

3 - FIXATION AU PLAFOND - FITTING TO CEILING
FIJACIÓN EN EL TECHO - DECKENBEFESTIGUNG

① > ② > ③ > ④

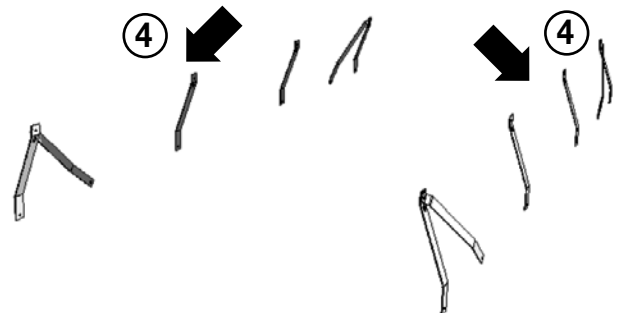
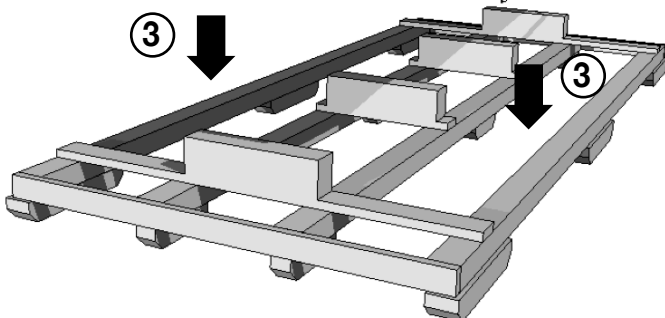
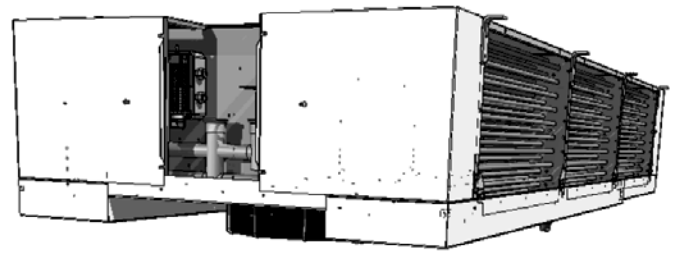
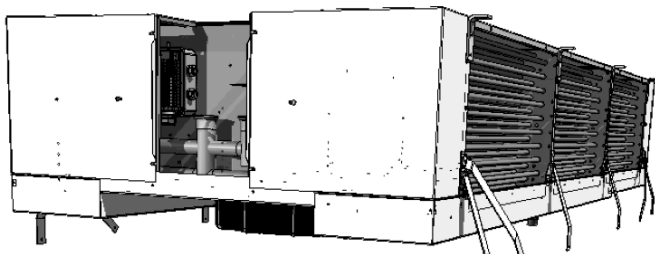
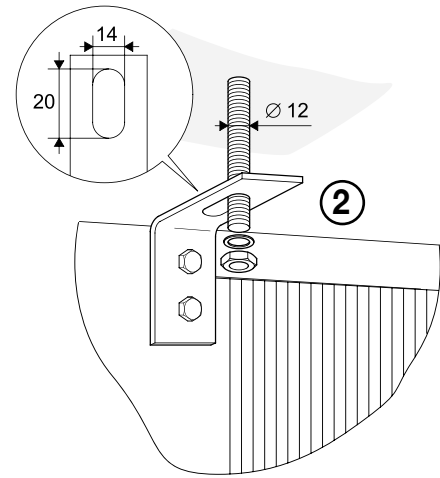
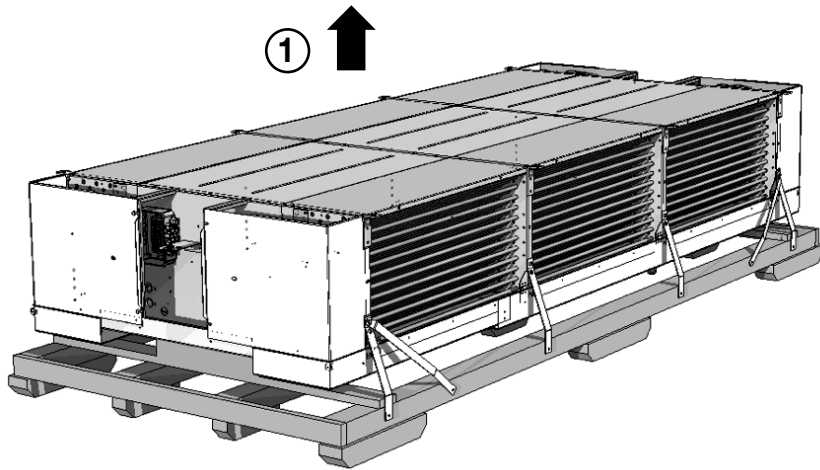

4 - PRECAUTION D'EMPLOI - PRECAUTION FOR USE
 PRECAUCION DE EMPLEO - VORSICHTSMABNHMEN

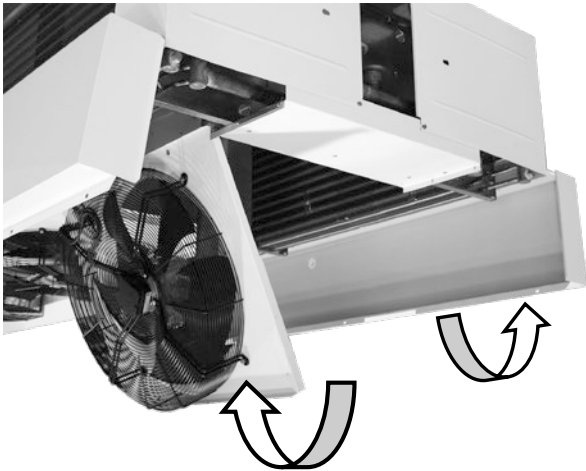



**ATTENTION ROTATION DE L'EGOUTTOIR
 BE CAREFUL ROTATION DRIP PAN
 ATENCIÓN ROTACIÓN DEL ESCURRIDERO
 ACHTUNG UMDREHUNG GESCHIRRKORB**

5 - RACCORDEMENT FRIGORIFIQUE - MISE EN PLACE BULBE ET EGALISATION DE PRESSION
 REFRIGERANT PIPING - BULB AND EXTERNAL EQUALIZER LAY-OUT
 CONEXIONES FRIGORÍFICAS - INSTALACION BULBO E IGUALACION DE PRESION
 KÄLTEMITTELANSCHLUSS - INSTALLATION DES FÜHLERS UND DES DRUCKAUSGLEICHSSCHLAUCHS

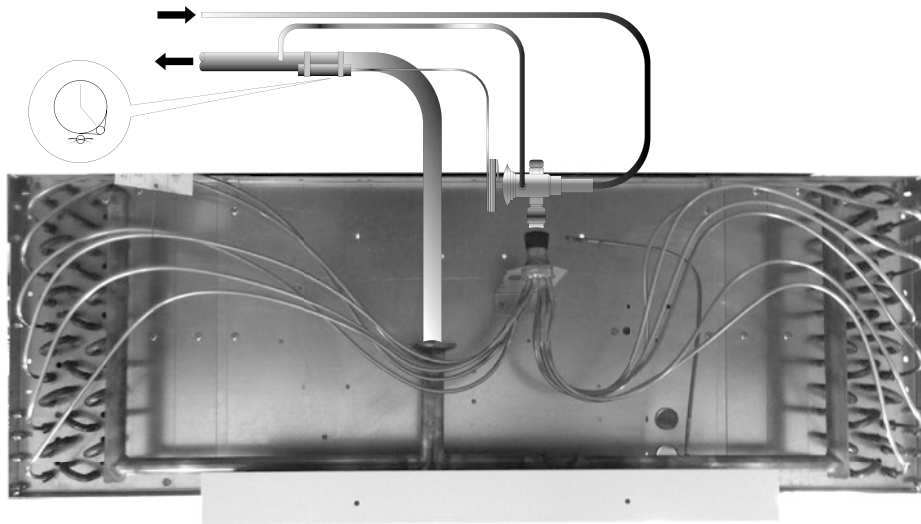

6 - RACCORDEMENT ELECTRIQUE - ELECTRICAL CONNECTION
 CONEXIÓN ELECTRICA - ELEKTRISCHE ANSCHLÜSSE

6.1 - VENTILATEURS
 FANS
 VENTILADORES
 VENTILATOREN

STANDARD

Caja de conexiones motor
 Boite à bornes moteur
 Motor terminal box

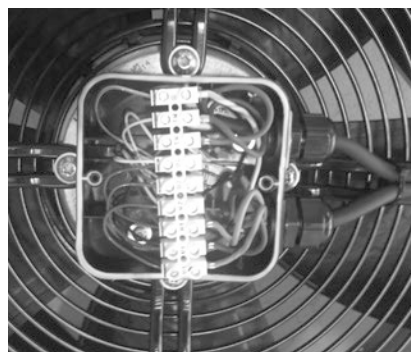

TK = Protector térmico
 Protection thermique
 Thermal overload protector

OPCION CMU
 OPTION CMU
 CMU OPTION

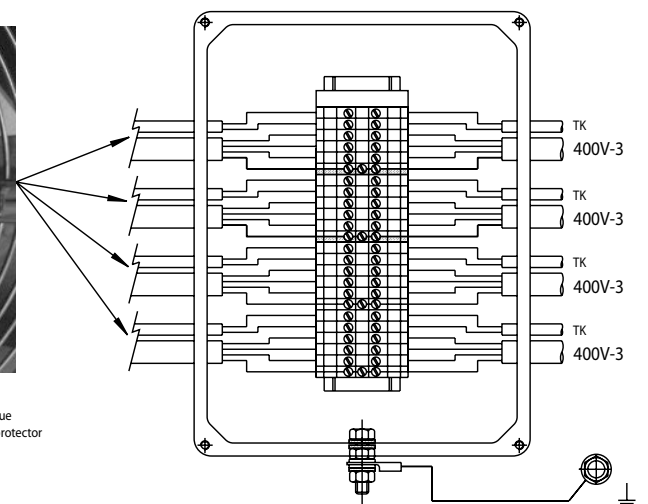

6.2 - VENTILATEURS - FANS
VENTILADORES - VENTILATOREN
EC1

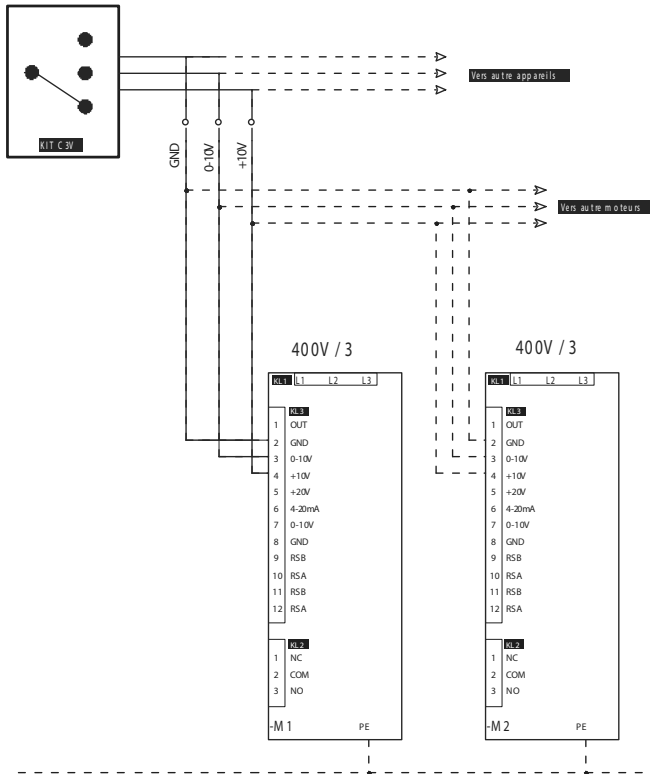

6.3 - VENTILATEURS - FANS
VENTILADORES - VENTILATOREN
EC2

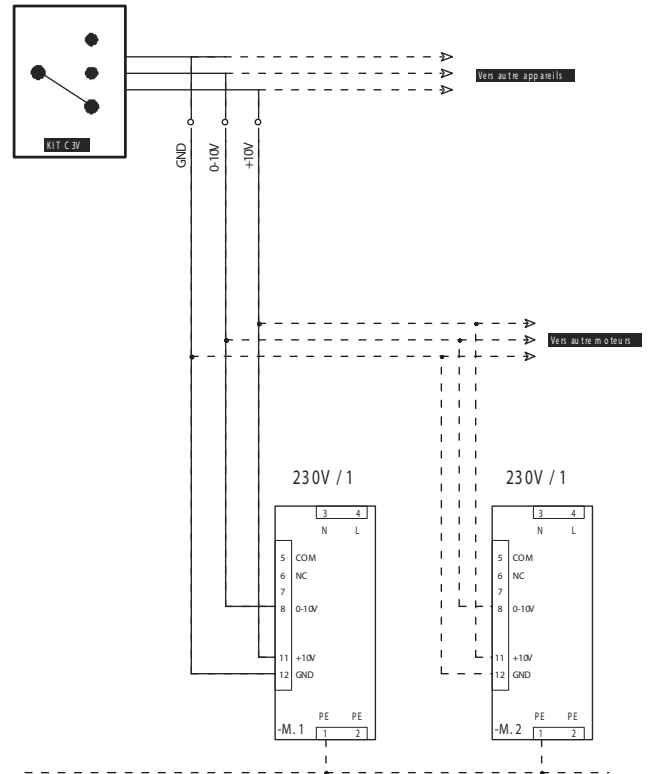

EC1 / CMU

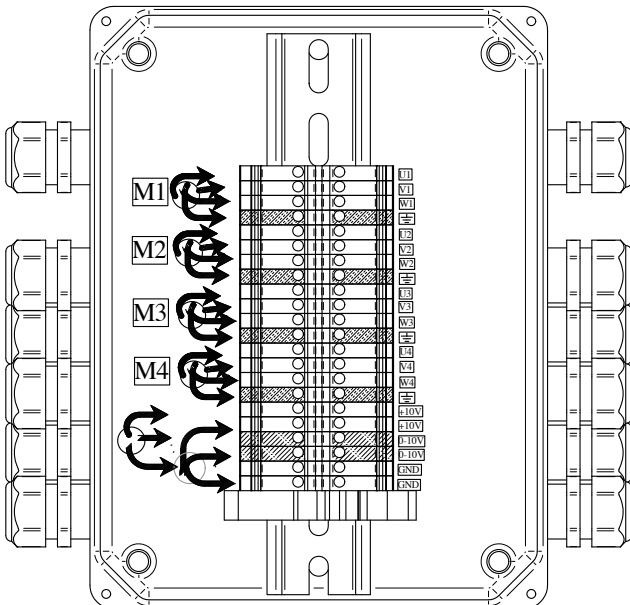
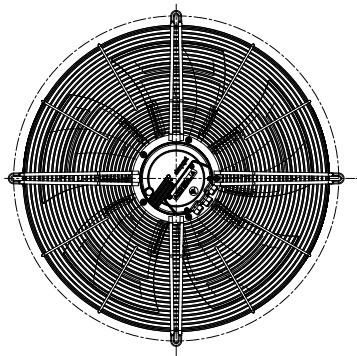

EC2 / CMU

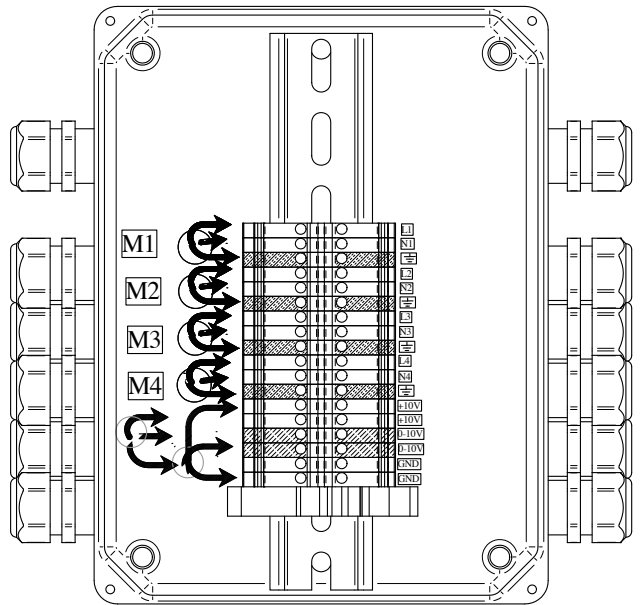
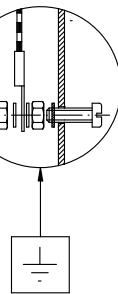
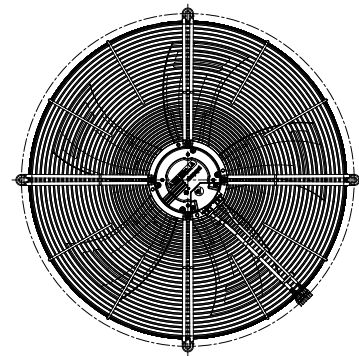

6.4 - RESISTANCES ELECTRIQUES - ELECTRICAL HEATERS RESISTENCIAS ELECTRICAS - ELEKTRISCHE HEIZUNGEN

OPCION HG1 - OPTION HG1 - HG1 OPTION

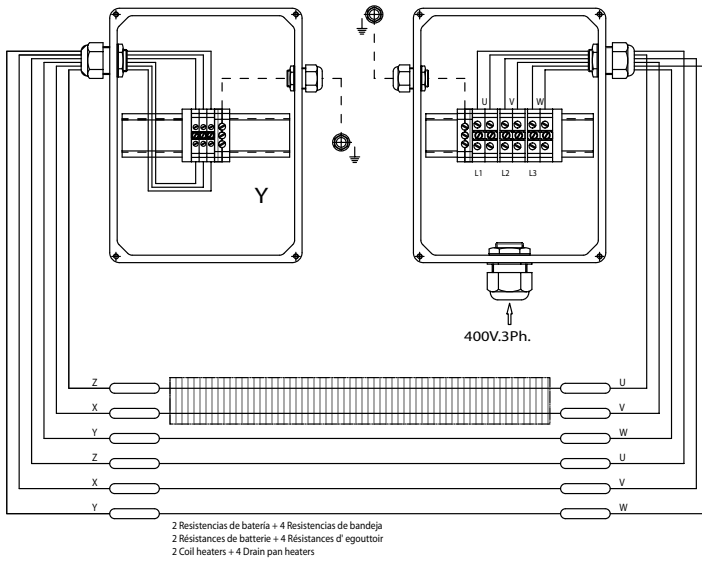

OPCION E1U - OPTION E1U - E1U OPTION

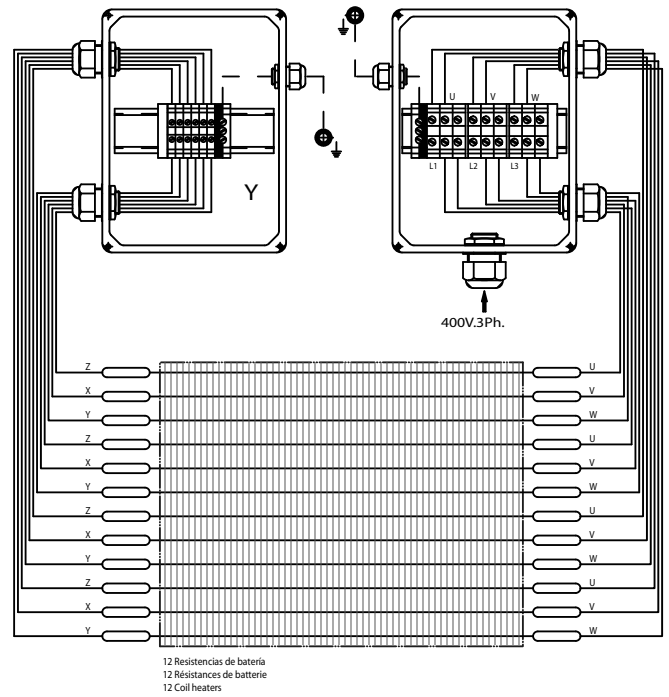

OPCION ELU - OPTION ELU - ELU OPTION

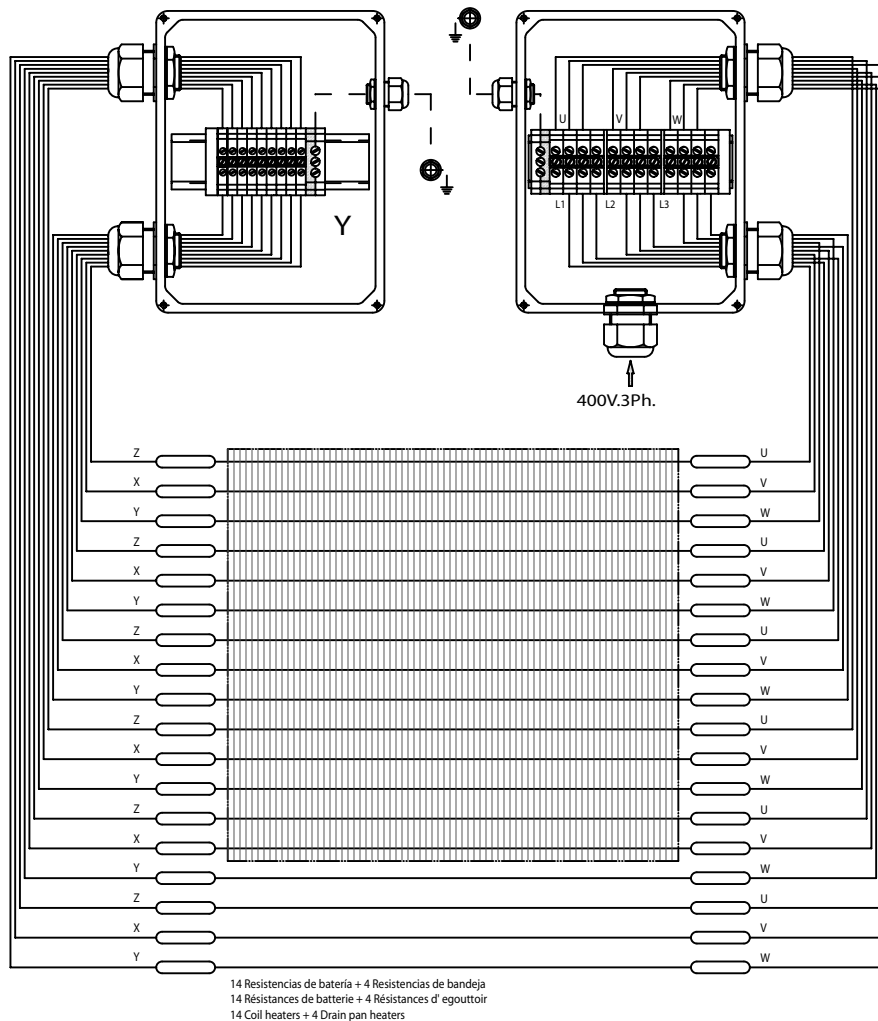

7 - ENTRETIEN

Nettoyer périodiquement à l'aide d'un produit non agressif et rincer à l'eau claire :

- la batterie : protéger les moteurs à l'aide d'un film plastique, pression maximale 3 bars et jet orienté face à la tranche des ailettes.
- la carrosserie.

Vérifier à la mise en route et périodiquement, le serrage des vis d'assemblage, l'état et le serrage des composants électriques.

DEFAUT DE FONCTIONNEMENT

Le moteur ne tourne pas : avant toute intervention, vérifier l'alimentation électrique. S'assurer que le ventilateur tourne librement.

L'appareil vibre : vérifier les ventilateurs.

7 - MAINTENANCE

Clean periodically with a non aggressive solution and rinse with clean water:

- coil: protect the motors with a plastic film, maximum 3 bars water pressure and jet facing the fin edges.
- casing.

At start up and periodically, check for eventual loosen screws, the condition and tightening of the electrical connections.

FAILURES

Motor does not run: before any intervention, check the electrical supply. Make sure that the fan is turning freely.

The unit vibrates: check the fans.

7 - MANTENIMIENTO

Limpié periódicamente con un producto no agresivo y aclare con agua limpia:

- la batería: proteja los motores con un celofán plástico, presión máxima 3 bares y chorro orientado frente al tramo de las aletas.
- la carrocería.

Verifique la puesta en marcha y periódicamente, la sujeción de los tornillos de ensambladura, el estado y la sujeción de los componentes eléctricos.

FALLO DE FUNCIONAMIENTO

El motor no funciona: antes de cualquier intervención, verifique la alimentación eléctrica. Asegúrese de que la ventilador gire libremente.

El aparato vibra: verifique los ventiladores, asegúrese de que no haya hielo en los alabes.

7 - WARTUNG

Folgende Teile regelmäßig mit einem milden Reinigungsmittel reinigen und mit klarem Wasser spülen:

- Batterie: Motoren mit einer Plastikfolie schützen, maximaler Druck des Wasserstrahls, der senkrecht zur Kante der Lamellen gerichtet sein muß: 3 Bar.
- Gehäuse.

Bei der Inbetriebnahme regelmäßig prüfen, ob alle Schrauben gut festgezogen sind. Zustand und Befestigung der elektrischen Komponenten überprüfen.

STÖRUNGEN

Der Motor läuft nicht: vor jeglichem Eingriff Stromversorgung überprüfen. Prüfen, ob sich die Ventilatoren leichtgängig drehen.

Das Gerät vibriert: Ventilatoren überprüfen. Sicherstellen, daß die Ventilatoren nicht vereist sind.



TPI Klimatimport AB
www.tpiab.com
info@tpiab.com

42 rue Roger Salengro - BP 205
69741 GENAS CEDEX - FRANCE
Tél. : + 33 4 72 47 13 00 - Fax : + 33 4 72 47 13 96
Internet : www.heatcrafteurope.com

LENNOX EMEA se réserve le droit d'apporter toute modification sans préavis.
LENNOX EMEA reserves itself the right to make changes at any time without preliminary notice.
LENNOX EMEA Angaben und Abbildungen unverbindlich. Änderungen vorbehalten.
LENNOX EMEA se reserva el derecho de aportar cualquier modificación sin preaviso.