



BUILT IN IMMERSED ELECTRODES HUMIDIFIER

USER MANUAL

**THIS MANUAL REFERS TO THE FOLLOWING UNITS:
DIRECT EXPANSION AND CHILLED WATER AIR CONDITIONERS WITH
ACCESSORY "INTERNAL HUMIDIFIER"**





INDEX

1	PURPOSE OF THIS MANUAL	5
2	COMPONENTS DESCRIPTION	6
3	PIPE CONNECTION AND INLET WATER CHARACTERISTIC	8
3.1	PIPE CONNECTIONS	8
3.2	WATER CIRCUIT CHARACTERISTIC	8
3.3	INLET WATER CHARACTERISTIC	9
4	OPERATING PRINCIPLES, CONTROL AND OTHER FUNCTIONS	10
4.1	ATER CONDUCTIVITY CONTROL	10
4.2	HIGH LEVEL SENSOR	10
4.2.1	FOAM PRESENCE CONTROL	10
4.3	CURRENT PEAK VALUE CONTROL	10
4.4	DRAINING MODE	11
4.4.2	MANUAL DRAINING MODE	11
4.5	PRE-WASH FUNCTION	11
5	HUMIDIFIER ALARM	12
5.1	μAC MICROPROCESSOR (CP4)	12
5.2	pCO MICROPROCESSOR	14
6	MAINTENANCE AND CYLINDER REPLACING	16
6.1	HUMIDIFIER COMPONENT DESCRIPTION (MAINTENANCE)	16
6.2	PERIODICAL MAINTENANCE	17
6.3	REPLACING THE CYLINDER	17
6.4	OTHER IDRAULIC COMPONENT MAINTENANCE	18
7	TROUBLE ANALYSIS	19
7.1	CHECK AND SOLVE THE HUMIDIFIER PROBLEM	19
8	NOTE	22



1 PURPOSE OF THIS MANUAL

This handbook introduces you to the installation, use and maintenance procedure of the internal humidifier. In the following chapter we will explain some points of extreme importance so to allow you to use this unit in the best way.

Therefore TECNAIR LV suggests you to take a deepened reading of this handbook.

Some of the arguments refer to operation modality, components and accessories of the unit that are not described in this handbook.

For these TECNAIR LV suggests to read the **MICROPROCESSOR USE** handbook, placed in the unit.

If, after the reading of this handbook, you still find yourselves in a situation of difficulty do not hesitate to contact our after sales service:

2 COMPONENTS DESCRIPTION

The internal humidifier with immersed electrodes are following made:

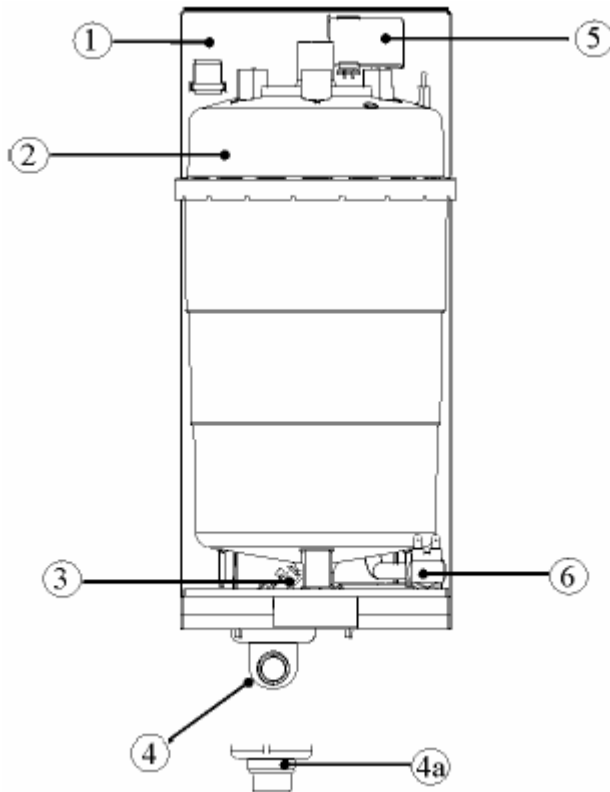

N°	DESCRIPTION
1	Bearing frame
2	Cylinder
3	Drain solenoid valve
4	90° revolving drain connection
4a	Straight drain connection (optional)
5	Conductimeter + Fill tank
6	Fill solenoid valve

Component details:

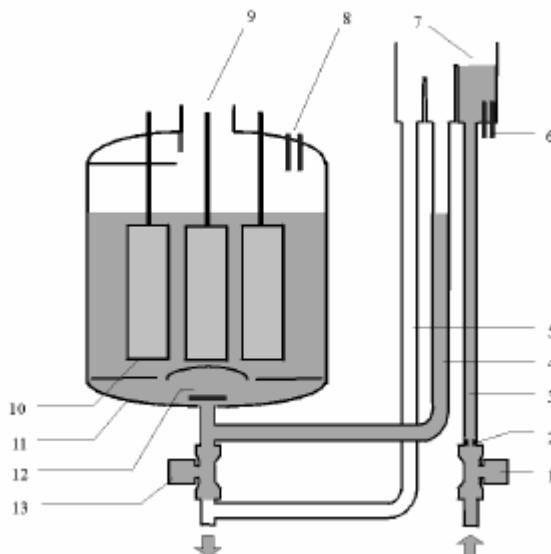

N°	DESCRIPTION
1	Fill solenoid valve
2	Flow rate limit device
3	Supply pipe
4	Fill pipe
5	Overflow pipe
6	Conductivity measuring electrodes
7	Fill tank – overflow device*
8	High level electrodes
9	Steam outlet
10	Electrodes (2/6 mono-phase, 3/6 three-phase)
11	Cylinder casing
12	Bottom filter
13	Drain solenoid valve

* Device used to avoid water overflowing from the fill tank above the safety level (for example if there are a malfunction of the controller or a leakage on the fill valve).
The fill tank is equipped with an overflow septum that discharges the excess water through a special pipe. The overflow septum is located in a lower position than the fill one (-40mm) to avoid back-flow into the fill pipe.

μAC electronic regulation board:

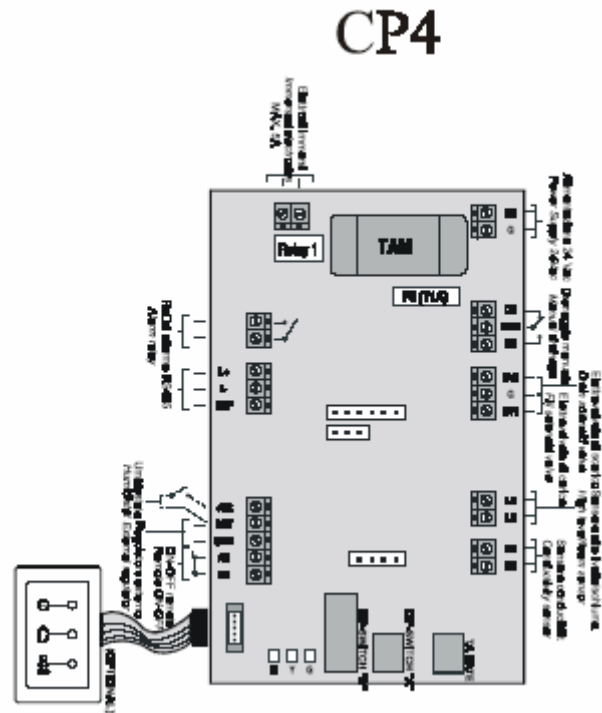

pCO electronic regulation board end TAM:



PCOUMID200



EXTERNAL TAM

3 PIPE CONNECTION AND INLET WATER CHARACTERISTIC

3.1 PIPE CONNECTIONS

During the installation of the unit is requested the connection of the inlet water pipe (see picture below) with the follow caracterisc. The draining pipe is installed by TECNAIR LV.

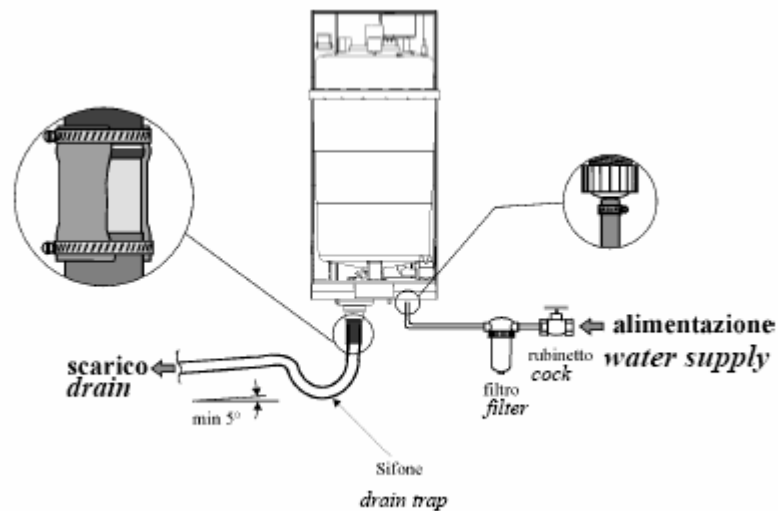

3.2 WATER CIRCUIT CHARACTERISTIC

These condition satisfy a good idric circuit:

- Line interrupted by a intercept water tap
- Installation of a mechanical filter on the inlet water
- Water temperature and pressure on the accetable limit

IMPORTANT WARNING: upon installation completion, drain the supply pipe for approximately 30 minutes by piping the water directly into the drain connection without sending it into the umidifier. This operation avoid any possible residual product that could clog the fill valve and/or produce foam during boiling.

3.3 INLET WATER CHARACTERISTIC

The humidifier need normal water whit the following caracteristic:

- Pressare between 0.1 and 0.8 Mpa (1-8 bar, 14.5-116 PSI)
- Temperature between 1 and 40 °C
- Istant flow rate not lower than the fill solenoid valve rated flow rate (0.6 – 1.2 l/m)
- Connection type ¾”G Male

LIMIT VALUES FOR MEDIUM-HIGH CONDUCTIVITY SUPPLY WATER OF A HUMIDIFIER WITH IMMERSSED ELECTRODES				LIMITS	
				Min.	Max.
Hydrogen ions	pH	-		7	8,5
Specific conductivity at 20 °C	σ_R , 20 °C	-	$\mu\text{S/cm}$	300	1250
Total dissolved solids	TDS	-	mg/l	(1)	(1)
Dry residue at 180 °C	R ₁₈₀	-	mg/l	(1)	(1)
Total hardness	TH	-	mg/l CaCO ₃	100 (2)	400
Temporary hardness		-	mg/l CaCO ₃	60(3)	300
Iron + Manganese		-	mg/l Fe □ Mn	0	0,2
Chlorides		-	Ppm Cl	0	30
Silica		-	mg/l SiO ₂	0	20
Residual chlorine		-	mg/l Cl	0	0,2
Calcium sulphate		-	mg/l CaSO ₄	0	100
Metallic impurities		-	mg/l	0	0
Solvents, diluents, soaps, lubricants		-	mg/l	0	0

LIMIT VALUES FOR MEDIUM-LOW CONDUCTIVITY SUPPLY WATER OF A HUMIDIFIER WITH IMMERSSED ELECTRODES				LIMITS	
				Min.	Max.
Hydrogen ions	pH	-		7	8,5
Specific conductivity at 20 °C	σ_R , 20 °C	-	$\mu\text{S/cm}$	125	500
Total dissolved solids	TDS	-	mg/l	(1)	(1)
Dry residue at 180 °C	R ₁₈₀	-	mg/l	(1)	(1)
Total hardness	TH	-	mg/l CaCO ₃	50 (2)	250
Temporary hardness		-	mg/l CaCO ₃	30(3)	150
Iron + Manganese		-	mg/l Fe □ Mn	0	0,2
Chlorides		-	Ppm Cl	0	20
Silica		-	mg/l SiO ₂	0	20
Residual chlorine		-	mg/l Cl	0	0,2
Calcium sulphate		-	mg/l CaSO ₄	0	60
Metallic impurities		-	mg/l	0	0
Solvents, diluents, soaps, lubricants		-	mg/l	0	0

(1) Values depending on specific conductivity; in general: TDS \cong 0.93 * σ_{20} ; R₁₈₀ @ 0.65 * σ_{20}

(2) not lower than 200% of chlorides content in mg/l of Cl-

(3) not lower than 300% of chlorides content in mg/l of Cl-

Warning: no relation can be demonstrated between water hardness and conductivity.

IMPORTANT WARNING! DO NOT TREAT WATER WHITH SOFTENERS!

This could cause corrosion of the electrodes or the formation of foam, leading to potential operative problem or failure.

Avoid:

1. Using well water, industrial water or water drawn from cooling circuits; in general, avoid using potentially contaminated water, either from a chemical or bacteriological point of view.
2. Adding disinfectants or corrosion inhibitors to water, as these substances are potentially irritant.

4 OPERATING PRINCIPLES, CONTROL AND OTHER FUNCTIONS

4.1 WATER CONDUCTIVITY CONTROL

The humidifier have a double control on the water conductivity. The first is made directly on the inlet water and the second on the cylinder water during the boiling.

The inlet water conductivity value is compared with two alarm threshold for the pre- alarm end alarm of high conductivity.

Is necessari don't go over this threshold to not compromise the good working of the humidifier, in this case the software give a pre-alarm end if the problem continue stop completely the production.

The second control is made directly on the water of the cylinder. During the boiling and the evaporation the conductivity of the water increase for the concentration of the salts. This measuring is indirect by the reduction time of the current from the nominal value to the -5%. This time is compared with a nominal one (one for each cylinder) and, if it is lower is make a draining (dilution draining) of a certain quantity of water and re-fill a lower conductivity fresh water.

Shuld remeber that the value of conductivity under the I/O loop is the inlet water value and it is re-fresh at each filling phases.

4.2 HIGH LEVEL SENSOR

The high level alarm can be made by one of the following problem:

- Total filling of the cylinder – with humidifier OFF – foe a leakage on the fill solenoid valve
- For the high level on the first start-up filling
- For the cylinder full of limestone
- For the foam on the cylinder, totally indipendent by the water level

For all of these problem the internal algorithm start a specific procedure to come beck to the normal working. On the last three case the humidifier start the low production phase.

4.2.1 FOAM PRESENCE CONTROL

If the high level sensors are touched by the water, the internal function are not able to recognise if it is water or foam.

If after few draining cycle and few stabilization cycle the sensors are already covered, then start the anti-foam cycle (if the alarm situation remain the umidifier start a complete washing cycle [complete draining → complete fill → complete draining])

If after the wasing cycle, the electrodes are already covered and another cycle is necessary, then the system give the alarm of **PRESENCE OF FOAM**.

4.3 CURRENT PEAK VALUE CONTROL

Any time the humidifier is activated is possible see, for a short time, a big peak value of current.

On the system, this peak value of current, can be accepted for the first 60 second with this limitation:

- If the current is **In*170%** bigger then the nominal one, there are a HIGH CURRENT DRAINING. At the end of the draining the humidifier restart.
- On the first 60 sec. for the second time , or over the 60 sec. for the first time, if the current is **In*150%** bigger then the nominal one, there are a 30 second draining. At the end of the draining there are a “HIGH CURRENT” alarm.
- Over the 60 sec. if the current is always **In*130%** bigger then the nominal one. there are a HIGH CURRENT DRAINING for 5 seconds. At the end of the draining the humidifier restart. If the problem remain there are a “HIGH CURRENT” alarm.



4.4 DRAINING MODE

The draining is activated for depends on several factors (es. High level, high current , etc.) the difference between the draining type is the drain time.

The type of draining (DRAIN_MODE) are the follow:

- Set-point reduction draining.
- Drain for no current whith full cylinder.
- First high current drain
- Second high current drain on the first 60 sec.
- Drain before the enabling
- Default drain

4.4.1 AUTOMATIC DRAIN MODE

The humidifier have the follow automatic drain mode:

- Set-point reduction drain:** during this mode, in case the reduction of the set-point is more then 33%, the humidifier drain a little bit of water. This function is usefull to produce immediatly the right quantity of steam wen the set-point is drastically reduced. This function is always active.
- Inactivity drain:** the inactivity drain is usefull to empty the cylinder when the humidifier don't produce steam for a longer period (default 1 day). The function is actived by default, is possibile disabile and ch'ange the periode by the user loop.
- Periodic drain:** During the normal working, if the water is heavy hardness, the humidifier empty the cylinder after a settable period (default 24 hours). This function is usefull to drain the limeston and increase the life of the cylinder. in modo da favorire la fuoriuscita dei sedimenti. The function is actived by default, is possibile disabile and ch'ange the periode by the user loop.
- Dilution drain under tension:** During the steam production, the cumul of salt increase the internal conductivity and, for a good working, have to stay under certain limit. To make this the humidifier, in automatic way, make a little drain at the right time (called "**Dilution drain**") and fill a new water with a lower conductivity. During this drein by **default** the power is stopped, in this way the drained water have **not** tension. In this little period the production is stopped. Is possibile make the drain with tension, whith the main power on, disabling the parameter: Drain without tension.

4.4.2 MANUAL DRAINING MODE

The manual draining is usefull durino the maintenance, and any other activity on the cylinder, to remove any presence of water inside the cylinder.

The draining is different by the microprocessor installed:

- μAC:** To make the complete draining you have to press the apposite key inside the electrical panel for minimum 120s (see electrical wiring diagam).
- pCO:** To make the complete draining you have to enable the apposite parameter on the maintenance loop for minimum 120s. At the end of the draining disabile the parameter. (See the use manual of the microprocessor).

4.5 PRE-WASH FUNCTION

Is possibile enable this function during the periodic maintenance. This function have two different working phases:

- Whith power OFF, the drain valve and the fill valve are opened for a certain time how depends on the cylinder capacity. This phase is necessary to clean-up the pipe and the solenoid valve.
- Three full filling phases and relative draining phases whith the power on. This phase is necessary to clean-up the wall and the electrodes of the cylinder.

5 HUMIDIFIER ALARM

In this chapter are explained all the alarm how you can have on the humidifier, the possible reasons and the solution.

5.1 μ AC MICROPROCESSOR (CP4)

On the μ AC microprocessor (CP4 humidifier board) the alarm are signalled by a flashing red led. The number of flashing give the possibility to understand the alarm type. In the table you can reach the explanation of the flashing.

Red LED flashes	Description & causes	Solution	Alarm		
			Type	Reset	Alarm relay
2 Short	Electrodes over-current: 1 Water conductivity too high (usually after a short stop) 2 High water level due to a drain valve malfunction 3 High water level due to a fill valve malfunction 4 Electrodes malfunction	1 Drain some water and re-start 2 Verify if the fill valve is properly working 3 Check for any leakage of the fill valve when the unit is OFF	Block	Manual	Active
3 Short	Not current on the electrodes: when the unit is on the steam is not produced	1 Check the external signal: Type (V or mA)? Value? Connection? 2 Switch OFF the unit, disconnect the power and check the internal wiring	Block	Manual	Active
4 Short	Internal memory error	1 Download the correct configuration by Humiset 2 If the problem remain please contact Carl assistance	Block	Manual	Active
5 Short	High conductivity on the inlet water	1 Control the parameter B6 by the RS485 connection 2 Switch OFF the unit and wash the conductivity electrodes 3 If the problem persists, change the source of supply water or install a suitable treatment system (demineralisation, even partial). NOTE: the problem will not be solved by softening the supply water.	Block	Manual	Active
2 Long	Cylinder depleted	Do maintenance and/or replace the cylinder	Signal	Manual	-
3 Long	Lack of supply water	1 Check that the fill pipe from the mains to the humidifier and the internal pipe are not blocked or bent and that there is sufficient supply pressure (0.1 to 0.8 MPa); 2 Check the fill valve is properly working; 3 Check for counter-pressure onto the steam hose higher than the maximum limit, preventing the entry by gravity of supply water into the cylinder; 4 Check that the steam outlet pipe is not is choked and that there is no condensate inside it	Disable	Manual	Active
4 Long	Excessive production reduction	Cylinder completely depleted or excessive foam. Do maintenance to the cylinder	Disable	Manual	Active
5 Long	Drain malfunction	Check the drain circuit and the proper operation of the drain valve	Disable	Manual	Active
6 Long	User parameters error	1 Download the correct configuration by Humiset 2 If the problem remain please contact Carl assistance	Block	Manual	Active



7 Long	Supply water high conductivity pre-alarm	<ol style="list-style-type: none"> 1 Check the conductivity of the supply water 2 Check the limit set by parameter b5 via RS485 3 If necessary, install a suitable demineralizer. <p>NOTE: the problem will not be solved by softening the supply water.</p>	Signal	Manua	-
8 Long	External command signal not properly connected (only 2 to 10V)	<ol style="list-style-type: none"> 1 Check the connection to the external regulator 2 Check the settings of parameters A0 and A2 via RS485 	Disable	Manua	Active
9 Long	Cylinder full with production not in progress	<p>With the OEM turned off:</p> <ol style="list-style-type: none"> 1 Check for any leaks from the fill valve or the condensate return pipe 2 Check that the level sensors are clean 	Disable	Manual	Active
10 Long	Foam inside the cylinder	<p>Foam is usually caused by surfactants in the water (lubricants, solvents, detergents, water treatment agents, softeners) or an excessive concentration of dissolved salts:</p> <ol style="list-style-type: none"> 1 Drain and clean the water supply pipes 2 Clean the cylinder 3 Check for the presence of softeners (in this case, use another type of supply water or reduce the softening) 	Signal	Manua	-
11 Long	Cylinder almost completely depleted	Do maintenance and/or replace the cylinder	Signal	Manua	-

5.2 pCO MICROPROCESSOR

On the pCO microprocessor the alarm reaching is automatic by the software. The problem are explained in the alarm mask of the display. In the follow table are explained the type of alarm:

ALARM	CAUSES	SOLUTION	RESET	ACTION
Cylinder empty of water	This alarm incoming: 1 During the fill if: • The maximum fill time is spired • If there are a strange value. 2 If during the pre-wash the water level don't tuch the high level electrodes.	1 Check the pressure of the fill pipe water (0.1÷0.8 MPa, 1÷8 bar); 2 Check the fill valve state; 3 Check if the steam pipe haven't a high counterpressure or a narrowing passage	Manual	Production stopped
Low production alarm	This alarm incoming if, durino the low production phases, the current at the end of the filling is lower then a calculated threshold.	Cylinder full of limestone or too high foam. Make the maintenance of the cylinder	Manual	Production stopped
Drain alarm	This alarm incoming during the drain: 1 If the current do not decrease; 2 If during a foam problem or a pre-wash the water tuch the high level sensor.	Check the drain valve or the drain pipe	Manual	Production stopped
High conductivity alarm	This alarm icoming if the threshold are exceed for 60 minute during the production or immediately if the water supply conductivity are 3 time bigger then the threshold.	Check and wash the conductivity sensor and, if the problem persist, change the type of water quality NOTE : The problem are not solved by the water softeners.	Manual	Production stopped
Low current alarm	It appear at the follow situations: 1 During the fill state. 2 If the difference between the initial current and the measuring current is different of a limit caluced by the target current, or if is at full 3 If the water touch the high level 4 If the current is minor then a limit calculated on the target current	Whit the unit OFF and the main power OFF check the internal wiring connection	Manual	Production stopped
High current alarm	It appear at the follow situations: 1 If before 60 seconds there are one second peack of current over the 150% of the nominal, there are a draining of 30s. At the and of the draining the Humidificator was stopped and the unit give the alarm. 2 If, over the first 60s, the current reach the 130% of the nominal.	1 Check the drain valve working 2 Check if there are some lickages on the fill valve 3 Drain some water and restart the unit	Manual	Production stopped



Foam alarm	<p>This alarm incoming:</p> <ol style="list-style-type: none"> 1 If after a the anti-foam cycle (Drain → Fill → Drain) the water tuch the high level sensor; 2 If after a complete washing the high level sensor are already tuched. 	<ol style="list-style-type: none"> 1 Wash the fill pipe 2 Wash the cylinder 3 Check the presence of a salt reducer and disable them 	Manual	Production stopped
Cylinder full of water	<p>This alarm incoming if the water tuch the high level sensor when:</p> <ol style="list-style-type: none"> 1 the unit is in OFF position or the humidifier is disabled; 2 the first phase of the pre-wash are not finished 	Check if the fill valve have no lckage or the electrodes are clean.	Manual	Production stopped
Full cylinder pre-alarm	<p>This alarm incoming if after some cycle of stabilizing the production parameter are higher that certain internal parameter.</p>	Make the periodical maintenance	Manual	Only signal
Full cylinder alarm	<p>This alarm incoming if after 3 hours after the full cylinder pre alarm the parameter are already over the threshold</p>	Change or wash the cylinder	Manual	Only signal

6 MAINTENANCE AND CYLINDER REPLACING



CAUTION!
BEFORE ALL WORKS PUT THE MAIN SWITCH
IN POSITION "O"



6.1 HUMIDIFIER COMPONENT DESCRIPTION (MAINTENANCE)

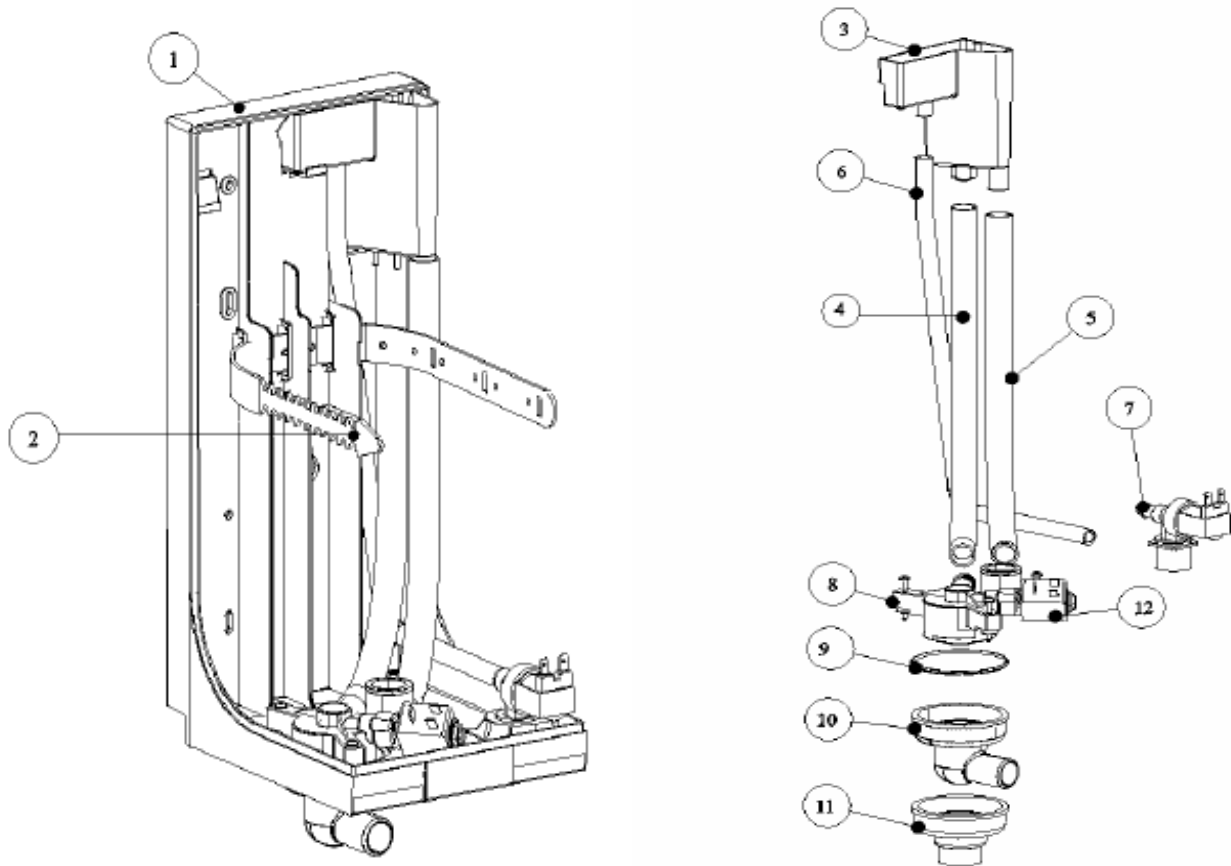

In the table are described the component:

N°	DESCRIPTION
1	Main structure
2	Cylinder blocking system
3	Fill box + conductimeter
4	Full pipe
5	Cylinder fill pipe
6	Fill box pipe
7	Fill valve
8	Fill/drain group
9	O-Ring
10	90° revolving drain connection
11	Straight drain connection (optional)
12	Drain valve

6.2 PERIODICAL MAINTENANCE

The humidifier need some periodical checking to increase the life of the cylinder and improve the working modus. The checking are be made as follow:

- ❑ **Every fortnight and no more than 300 working hours**
For both the disposable and openable cylinders, check that no significant water leak is present and verify cylinder operation and the general conditions of the container. Also check that no arc or spark originate between the electrodes when the machine is operating.
- ❑ **Every three months and no more than 1,000 working hours**
For disposable cylinders, verify cylinder operation, check that no significant water leak is present and replace the cylinder, if required. For openable cylinders, check the container for markedly blackened areas: in case they are present, check the scale condition of the electrodes and, if necessary, replace them together with the O-rings and the cover gasket.
- ❑ **Every year and no more than 2,500 working hours**
For disposable cylinders, replace the cylinder. For openable cylinders, check that no significant water leak is present, verify cylinder operation and the general conditions of the container. Also check the container for markedly blackened areas: in case they are present, replace the electrodes together with the O-rings and the cover gasket.

After extended use or due to the use of water with a high salt content, the solid deposits that form naturally on the electrodes might spread until they cover the cylinder internal wall. In case particularly conductive deposits form, the heat consequently produced might overheat plastic and melt it; in the most severe cases, heat might perforate plastic, causing the water to leak from the cylinder to the tank.

As a precaution, check the quantity of deposits and verify that no deformation or blackening is present on the wall of the cylinder, otherwise replace it.

6.3 REPLACING THE CYLINDER

IMPORTANT WARNING: the cylinder might be hot: before touching it, let it cool or use protective gloves.

The duration of the cylinder depends on different factors, including: complete filling with limestone and/or partial or total corrosion of the electrodes, proper use and dimensioning of the humidifier, working output, water quality, careful and regular maintenance.

After a variable period is necessary replace the cylinder. To made this operation in the proper way please respect the following instruction.

IMPORTANT WARNING: all service and/or maintenance operations must be carried out by specialist and qualified personnel aware of the necessary precautions.

To replacing the cylinder:

- 1) Place the unit in OFF position
- 2) Completely drain the water contained in the cylinder
- 3) Turn the appliance off and open the mains knife switch (**safety procedure**)
- 4) Remove the steam pipe from the cylinder
- 5) Disconnect the electrical connections from the top of the cylinder
- 6) Release the cylinder from the fasteners and lift it for removal
- 7) Assemble the new cylinder on the humidifier operating in reverse order.

6.4 OTHER IDRAULIC COMPONENT MAINTENANCE

WARNING:

- 1) For the plastic component washing do not use solvent or aggressive agent;
 - 2) To remove the limeston you can use vinegar or vinegar acid at 20%, after you can wash whit water.
 - 3) After the changing or the control of the component please check if all the connection are made in the right way. Start-up the unit and make some pre-wash cycle, then check if there are some water filling.
-
- Filling valve:** Disconnect the pipe and the elecric wire, remove the valve and check if the filter are clean; If necessary, wash it whit water and a soft brush.
 - Fill/Drain group:** Chek and wash the cylinder connection whit water. Check the O-ring status; if necessari change it.
 - Draining valve:** Disconnect the elecric wire and the draining pipe, remove the valve by the screw, wash it whit water and a soft brush.
 - Fill box and conducimeter:** Check if there are some limeston iside the connection and on the elecrodes; Wash it whit water.
 - Fill and high level pipe:** Check if there are some limeston iside and wash it whit water.



7 TROUBLE ANALYSIS



CAUTION!
BEFORE ALL WORKS PUT THE MAIN SWITCH
IN POSITION "O"



The following chapter aims at assisting the operator in searching possible troubles in the unit equipment. Starting from the type of problem in question, indication is given of the possible sequential causes of the trouble itself and the possible remedies. The description of the causes is general, so it takes into consideration the most complete possible versions of the units; the operator shall take care to identify, from time to time, only the matters of interest and/or the functions actually featured in the unit in question.

Any intervention on the unit shall be carried out only by competent skilled personnel.

We recommend not executing any kind of operation if you have not enough knowledge of the unit working principle.

7.1 CHECK AND SOLVE THE HUMIDIFIER PROBLEM

Legend of the failure diagram:



FAILURE

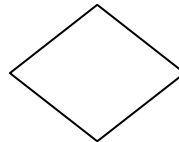

FUNCTION



CAUSE



REMEDY

